

Centre Number	Candidate Number	Name
---------------	------------------	------

CAMBRIDGE INTERNATIONAL EXAMINATIONS  
General Certificate of Education  
Advanced Subsidiary Level and Advanced Level

**CHEMISTRY**

**9701/04**

Paper 4 Structured Questions

May/June 2003

**1 hour**

Candidates answer on the Question Paper.

Additional Materials:

Data Booklet

**READ THESE INSTRUCTIONS FIRST**

Write your name, Centre number and candidate number in the spaces provided at the top of this page.

Write in dark blue or black pen in the spaces provided on the Question Paper.

You may use a pencil for any diagrams, graphs, or rough working.

Do not use staples, paper clips, highlighters, glue or correction fluid.

Answer **all** questions.

The number of marks is given in brackets [ ] at the end of each question or part question.

You may lose marks if you do not show your working or if you do not use appropriate units.

For Examiner's Use	
<b>1</b>	
<b>2</b>	
<b>3</b>	
<b>4</b>	
<b>5</b>	
<b>6</b>	
<b>TOTAL</b>	

If you have been given a label, look at the details. If any details are incorrect or missing, please fill in your correct details in the space given at the top of this page.

Stick your personal label here, if provided.

This document consists of **12** printed pages.



Answer **all** the questions in the spaces provided.

- 1 (a) What do you understand by the term *standard electrode potential*?

.....  
 .....[2]

- (b) The following cell was set up between a copper electrode and an unknown metal electrode  $M^{2+}(aq)/M(s)$ . The standard cell potential was found to be 0.76 V, and the copper foil was the positive electrode.

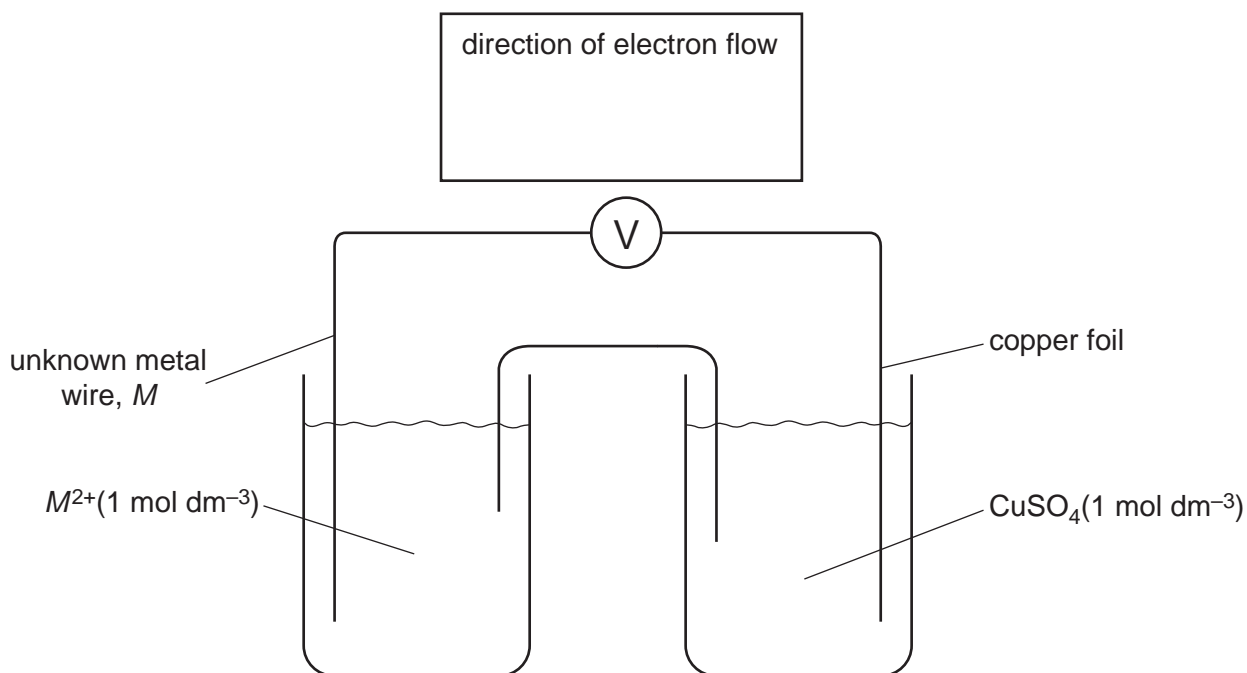

- (i) Use the *Data Booklet* to calculate the standard electrode potential of the  $M^{2+}(aq)/M(s)$  system.
- .....
- (ii) Draw an arrow over the voltmeter symbol in the above diagram to show the direction of electron flow through the voltmeter.
- (iii) Predict the outcomes of the following situations. Describe what you might see and write ionic equations for any reactions that occur.
- I A rod of metal  $M$  is dipped into a solution of  $1 \text{ mol dm}^{-3} \text{ CuSO}_4$ .

.....  
 .....  
 .....

- II Dilute sulphuric acid is added to a beaker containing a powdered sample of metal *M*.

.....

.....

.....

[6]

- (c) Because of its increased scarcity, cheaper copper ornaments are no longer made from the solid metal, but from iron that has been copper plated.

- (i) Complete the following diagram showing the set-up for a copper electroplating process. Show clearly the polarity (+/–) of the power source, and suggest a suitable electrolyte.

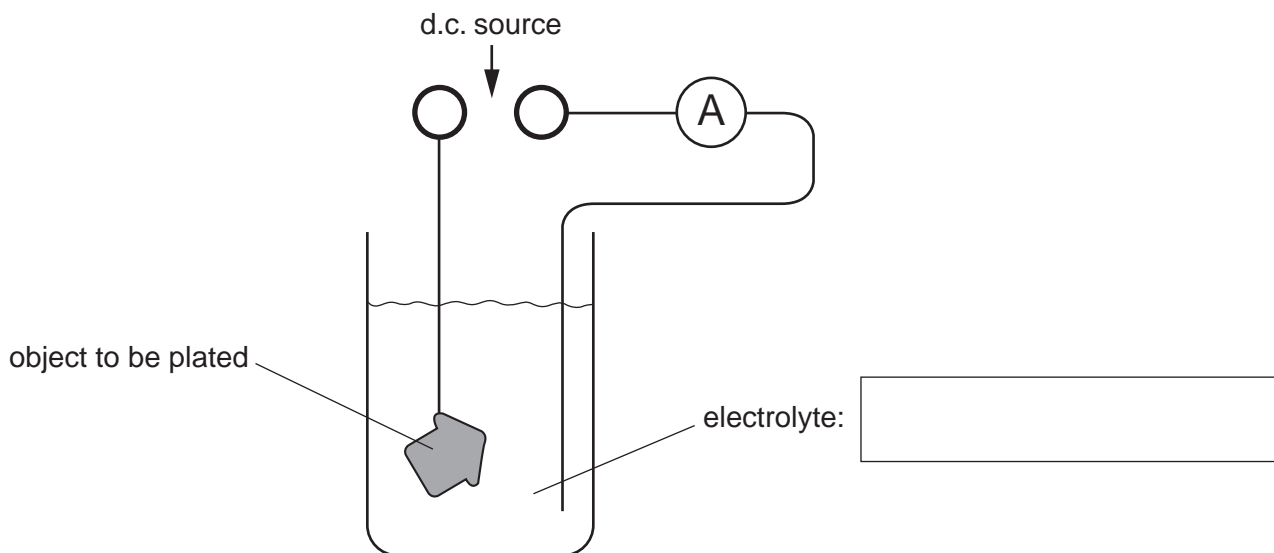

- (ii) A current of 0.500 A is passed through the electroplating cell. Calculate the time required to deposit a mass of 0.500 g of copper on to the ornament.

.....

.....

.....

[5]

[Total : 13]

- 2 (a) Barium ions are poisonous. Patients with digestive tract problems are sometimes given an X-ray after they have swallowed a 'barium meal', consisting of a suspension of  $\text{BaSO}_4$  in water. The  $[\text{Ba}^{2+}(\text{aq})]$  in a saturated solution of  $\text{BaSO}_4$  is too low to cause problems of toxicity.

(i) Write an expression for the solubility product,  $K_{\text{sp}}$ , for  $\text{BaSO}_4$ , including its units.

.....

(ii) The numerical value of  $K_{\text{sp}}$  is  $1.30 \times 10^{-10}$ . Calculate  $[\text{Ba}^{2+}(\text{aq})]$  in a saturated solution of  $\text{BaSO}_4$ .

.....

.....

(iii) The numerical value of  $K_{\text{sp}}$  for  $\text{BaCO}_3$  ( $5 \times 10^{-10}$ ) is not significantly higher than that for  $\text{BaSO}_4$ , but barium carbonate is **very** poisonous if ingested. Suggest a reason why this might be so.

.....

.....

[3]

- (b) A useful commercial source of magnesium is sea water, where  $[\text{Mg}^{2+}(\text{aq})]$  is  $0.054 \text{ mol dm}^{-3}$ . The magnesium is precipitated from solution by adding calcium hydroxide.

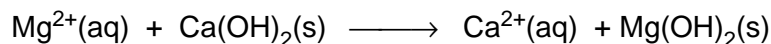

(i) Write an expression for the  $K_{\text{sp}}$  of  $\text{Mg}(\text{OH})_2$ , including its units.

.....

(ii) The numerical value for  $K_{\text{sp}}$  is  $2.00 \times 10^{-11}$ . Calculate  $[\text{Mg}^{2+}(\text{aq})]$  in a saturated solution of  $\text{Mg}(\text{OH})_2$ .

.....

.....

- (iii) Hence calculate the maximum percentage of the original magnesium in the seawater that this method can extract.

.....  
 .....

[5]

- (c) The magnesium ions in seawater are mainly associated with chloride ions.

- (i) Use the following  $\Delta H_f^\ominus$  values to calculate a value for the  $\Delta H^\ominus$  of the following reaction.



species	$\Delta H_f^\ominus / \text{kJ mol}^{-1}$
$\text{MgCl}_2(\text{s})$	-641
$\text{Mg}^{2+}(\text{aq})$	-467
$\text{Cl}^{-}(\text{aq})$	-167

.....  
 .....

- (ii) Use your answer to explain why  $\text{MgCl}_2$  is very soluble in water.

.....  
 .....

[2]

- (d) All the chlorides of Group II elements are soluble in water. The same is not true of their sulphates. These become less soluble as the group is descended.

Explain qualitatively the variation in solubility of the sulphates of the elements in Group II down the Group from magnesium to barium.

.....  
 .....

[2]

[Total : 12]

- 3 (a) The melting points of some oxides of Group IV elements are given below.

oxide	melting point / °C
CO <sub>2</sub>	-78
SiO <sub>2</sub>	1610
SnO <sub>2</sub>	1630

Describe the bonding in each oxide, and how it relates to its melting point.

- (i) CO<sub>2</sub>

.....  
.....  
.....

- (ii) SiO<sub>2</sub>

.....  
.....  
.....

- (iii) SnO<sub>2</sub>

.....  
.....  
.....

[3]

(b) Writing balanced equations where appropriate, describe how the above three oxides differ in their reactions with

(i) NaOH(aq),

.....  
.....  
.....

(ii) HCl(aq).

.....  
.....  
.....

[4]

(c) The last oxide in Group IV, PbO<sub>2</sub>, reacts with concentrated hydrochloric acid liberating chlorine gas.

Use the *Data Booklet* to calculate the  $E_{\text{cell}}^{\ominus}$  and to write a balanced equation for this reaction.

.....  
.....[2]

[Total : 9]

- 4 Chloroacetophenone (compound **D**, below) was formerly the most widely used tear gas, under the codename *CN*. It was used in warfare and in riot control. It can be synthesised from ethylbenzene, **A**, by the following route.

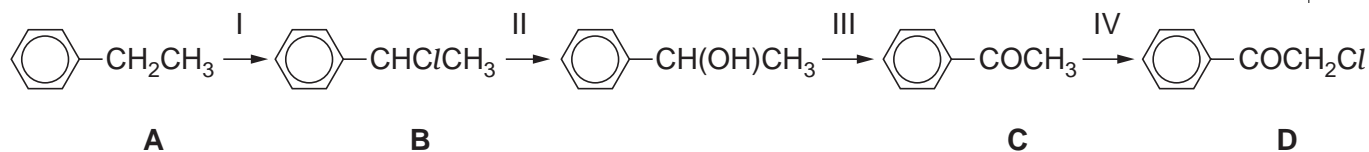

- (a) Suggest reagents and conditions for step I.

.....[1]

- (b) Suggest reagents and conditions for converting ethylbenzene into compound **E**, an isomer of **B**.

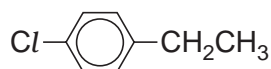

**E**

.....[1]

- (c) Draw the structure of the product obtained by heating ethylbenzene with  $\text{KMnO}_4$ .

[1]

- (d) Describe a test (reagents and observations) that would distinguish compound **C** from compound **F**.



**F**

reagents

.....

observation with **C**

.....

observation with **F**

.....

[2]



- (e) The efficiency of a tear gas is expressed by its 'intolerable concentration', I.C. The I.C. of the tear gas *CN* has been measured as  $0.030 \text{ g m}^{-3}$  of air. How many moles of chloroacetophenone need to be sprayed into a room of volume  $60 \text{ m}^3$  in order to achieve this concentration?

.....  
 .....  
 .....[2]

- (f) Residues of *CN* can be destroyed by hydrolysis with an aqueous alkali.



**D**

Compounds **G** and **H** are isomers of compound **D**.

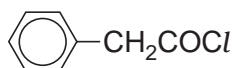

**G**

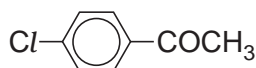

**H**

- (i) Arrange the three isomers **D**, **G** and **H** in order of increasing ease of hydrolysis.

.....

- (ii) Explain the reasoning behind your choice.

.....  
 .....  
 .....

[3]

[Total : 10]

- 5 (a) Acyl chlorides are useful intermediates for making various acid derivatives. The following reaction scheme shows some of the reactions of ethanoyl chloride.

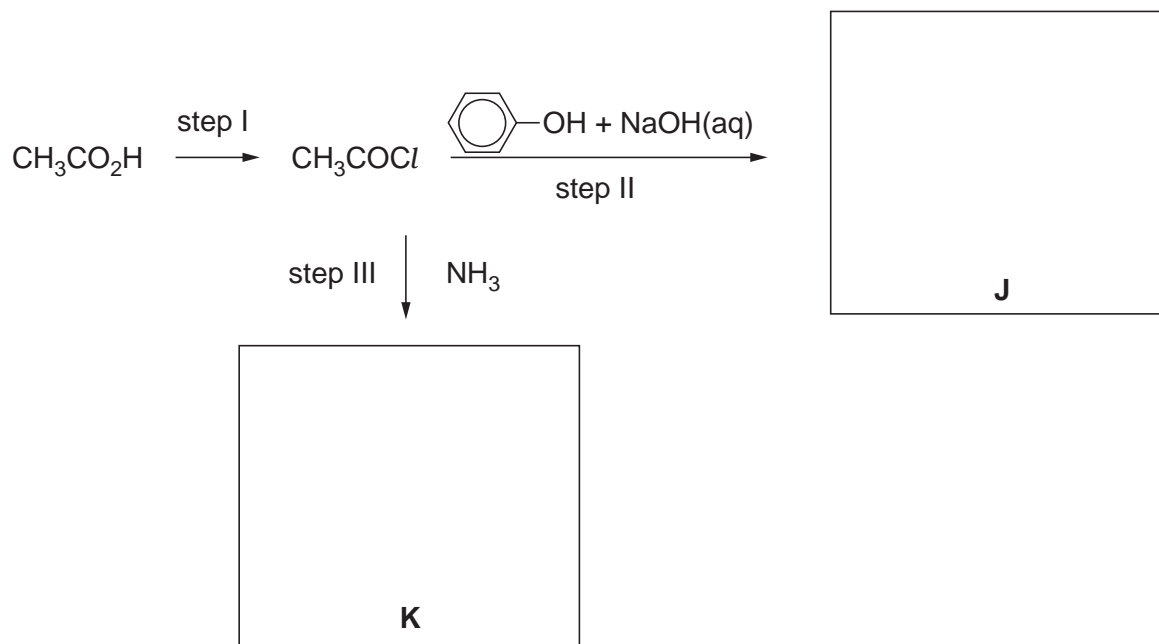

- (i) Suggest a reagent for step I.

.....

- (ii) Write an equation showing the reaction between phenol and NaOH(aq), the reagents in step II.

.....

- (iii) Draw the structural formulae of products **J** and **K** in the boxes above.

[4]

- (b) The diacid **L** occurs naturally and is used as a food additive to enhance the acidic flavour in some fruit drinks.

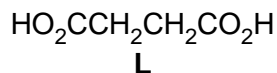

When the diacyl chloride of **L** is reacted with  $\text{HOCH}_2\text{CH}_2\text{OH}$ , a polymer is formed.

- (i) What type of polymerisation is occurring here?

.....

- (ii) Write an equation showing the reaction between **one** mole of the diacyl chloride of **L** and **two** moles of  $\text{HOCH}_2\text{CH}_2\text{OH}$ .

[3]

- (c) The following formula represents a section of another polymer.



- (i) What type of polymer is this?

.....

- (ii) Draw the structural formula of each of the monomers that make up this polymer.

[3]

[Total : 10]

- 6 (a) Titanium is an important transition metal. The metal itself is a component of many high-strength low-weight alloys, and its oxide is used as an opaque agent in many paints and pigments.

(i) Write out the electronic configuration of the titanium atom.

.....

(ii) Titanium forms two chlorides. Suggest possible formulae for them.

.....

[2]

- (b) Anhydrous copper sulphate,  $\text{CuSO}_4(\text{s})$ , is a white powder that readily dissolves in water.

(i) Describe and explain what is seen when  $\text{CuSO}_4(\text{s})$  is stirred with water.

.....

.....

.....

(ii) Describe and explain the final colour change seen when an excess of  $\text{NH}_3(\text{aq})$  is added to  $\text{CuSO}_4(\text{aq})$ .

.....

.....

.....

[4]

[Total : 6]