

UNIVERSITY OF CAMBRIDGE INTERNATIONAL EXAMINATIONS
International General Certificate of Secondary Education

CHEMISTRY

0620/01

Paper 1 Multiple Choice

May/June 2006

45 minutes

Additional Materials: Multiple Choice Answer Sheet
Soft clean eraser
Soft pencil (type B or HB is recommended)

READ THESE INSTRUCTIONS FIRST

Write in soft pencil.

Do not use staples, paper clips, highlighters, glue or correction fluid.

Write your name, Centre number and candidate number on the Answer Sheet in the spaces provided unless this has been done for you.

There are **forty** questions on this paper. Answer **all** questions. For each question there are four possible answers **A, B, C** and **D**.

Choose the **one** you consider correct and record your choice in **soft pencil** on the separate Answer Sheet.

Read the instructions on the Answer Sheet very carefully.

Each correct answer will score one mark. A mark will not be deducted for a wrong answer.

Any rough working should be done in this booklet.

A copy of the Periodic Table is printed on page 20.

You may use a calculator.

This document consists of **18** printed pages and **2** blank pages.



1 At room temperature, in which substance are the particles furthest apart?

- A H_2 B H_2O C Mg D MgO

2 Which method can be used to obtain crystals from aqueous copper(II) sulphate?

- A chromatography
B electrolysis
C evaporation
D neutralisation

3 Five elements have proton numbers 10, 12, 14, 16 and 18.

What are the proton numbers of the three elements that form oxides?

- A 10, 12 and 14
B 10, 14 and 18
C 12, 14 and 16
D 14, 16 and 18

4 The rows P, Q and R in the table show three pairs of structures.

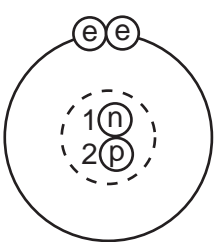
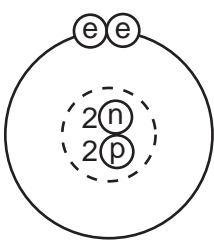
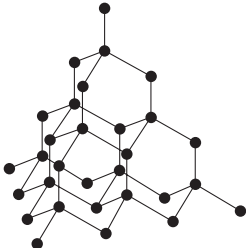
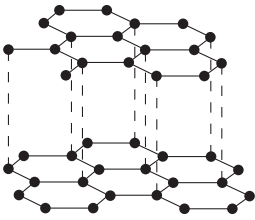
P			key ⓔ electron ⓓ neutron Ⓟ proton Ⓢ nucleus
Q			● atoms of the same element
R	$\begin{array}{c} \text{H} \\ \\ \text{H}-\text{C}-\text{H} \\ \\ \text{H} \end{array}$	$\begin{array}{c} \text{H} \quad \text{H} \\ \quad \\ \text{H}-\text{C}-\text{C}-\text{H} \\ \quad \\ \text{H} \quad \text{H} \end{array}$	

Which pair or pairs are isotopes?

- A P only B P and Q only C Q only D Q and R only

- 5 Which numbers are added to give the nucleon number of an ion?
- A number of electrons + number of neutrons
B number of electrons + number of protons
C number of electrons + number of protons + number of neutrons
D number of protons + number of neutrons
- 6 In the molecules CH_4 , HCl and H_2O , which atoms use **all** of their outer shell electrons in bonding?
- A C and Cl
B C and H
C Cl and H
D H and O
- 7 Which change to an atom occurs when it forms a positive ion?
- A It gains an electron.
B It gains a proton.
C It loses an electron.
D It loses a proton.
- 8 For which compound is the formula correct?

	compound	formula
A	ammonia	NH_4
B	carbon dioxide	CO
C	potassium oxide	P_2O
D	zinc chloride	ZnCl_2

- 9 The diagrams show the molecules of three elements.



1

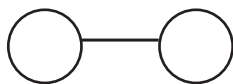

2



3

Which of these elements are present in water?

- A** 1 and 2 only
B 1 and 3 only
C 2 and 3 only
D 1, 2 and 3
- 10 The diagram shows that two gases are formed when concentrated hydrochloric acid is electrolysed between inert electrodes.

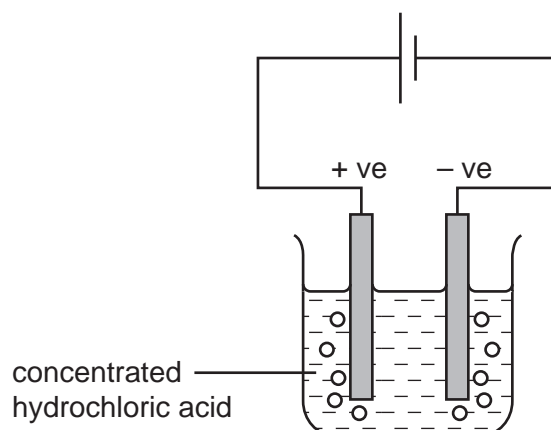

Which line correctly describes the colours of the gases at the electrodes?

	anode (+ve)	cathode (-ve)
A	colourless	colourless
B	colourless	yellow-green
C	yellow-green	colourless
D	yellow-green	yellow-green

- 11 The diagram shows an electrolysis experiment to electroplate nickel with a different metal.

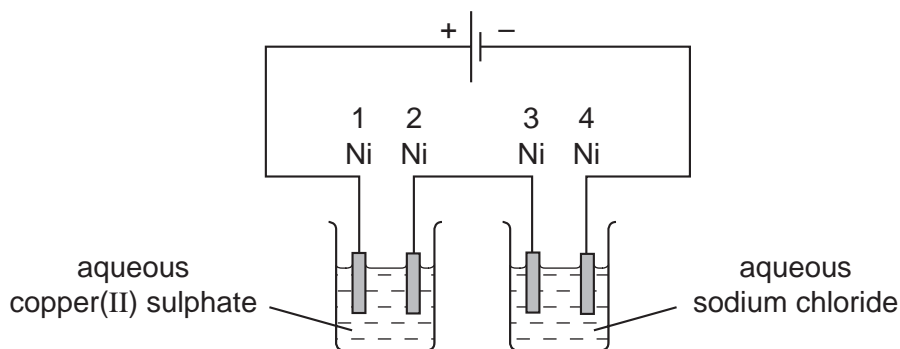

Which nickel electrodes are plated with a metal?

- A 1 only
 B 1 and 3 only
 C 2 only
 D 2 and 4 only
- 12 The diagram shows an experiment in which magnesium oxide powder is added to dilute hydrochloric acid.

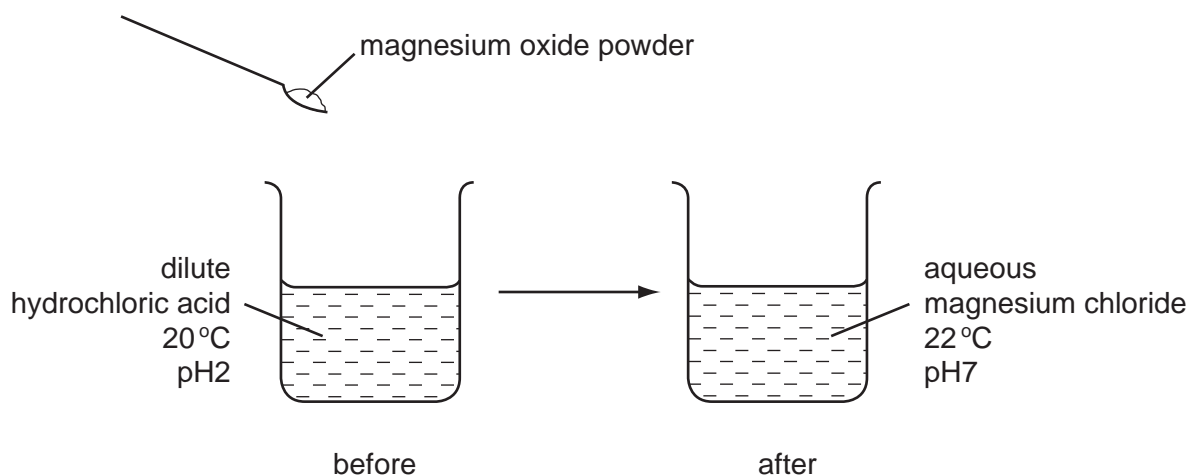

Which terms describe the experiment?

	exothermic	neutralisation
A	✓	✓
B	✓	x
C	x	✓
D	x	x

13 Coal, methane and hydrogen are burned as fuels.

Which descriptions of this process are correct?

	what happens to the fuel	type of reaction
A	oxidised	endothermic
B	oxidised	exothermic
C	reduced	endothermic
D	reduced	exothermic

14 Two reactions involving water are shown.

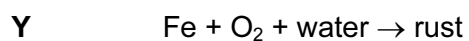
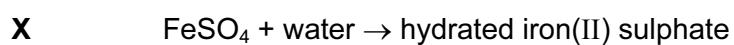

Which of these reactions are reversible by heating?

	X	Y
A	✓	✓
B	✓	x
C	x	✓
D	x	x

15 The diagram shows a speed of reaction experiment.

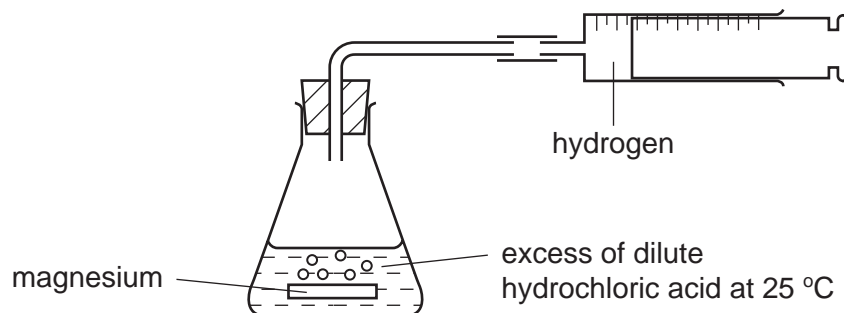

Increasing the concentration of the acid and increasing the temperature both affect the speed of reaction.

Which line of the table is correct?

	increase concentration of acid	increase temperature
A	decrease speed of reaction	decrease speed of reaction
B	decrease speed of reaction	increase speed of reaction
C	increase speed of reaction	decrease speed of reaction
D	increase speed of reaction	increase speed of reaction

16 Barium hydroxide is an alkali. It reacts with hydrochloric acid.

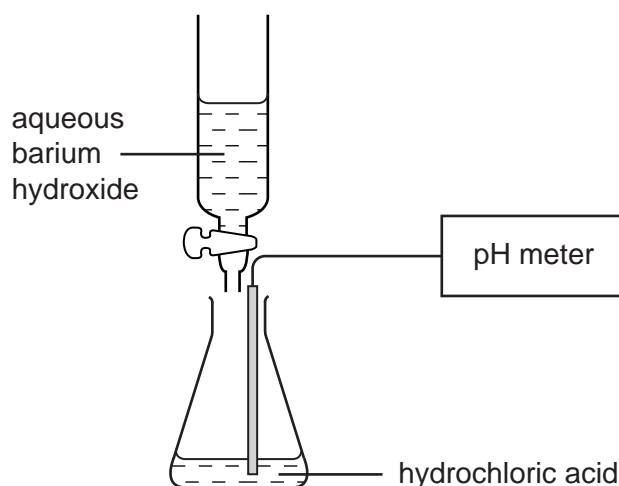

What happens to the pH of a solution of hydrochloric acid as an excess of aqueous barium hydroxide is added?

- A** The pH decreases from 14 but becomes constant at 7.
- B** The pH decreases from 14 to about 1.
- C** The pH increases from 1 but becomes constant at 7.
- D** The pH increases from 1 to about 14.

17 Element X is at the left-hand side of the Periodic Table.

Which line in the table shows the correct type and property of the oxide of X?

	type of oxide	property of oxide
A	metallic	acidic
B	metallic	basic
C	non-metallic	acidic
D	non-metallic	basic

18 The diagram shows the positions of some elements in the Periodic Table.

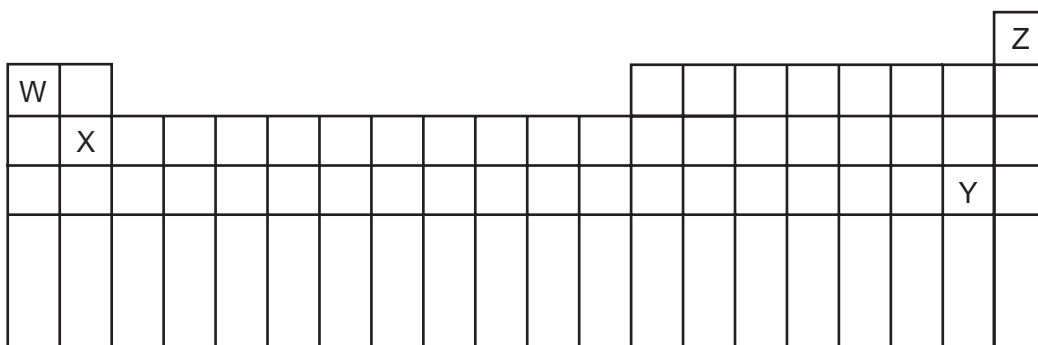

Which elements form ionic bonds with oxygen?

- A** W only
- B** W and X only
- C** Y only
- D** Y and Z only

- 19 The diagrams show three experiments using dilute sulphuric acid. Three different powders are added to the acid.

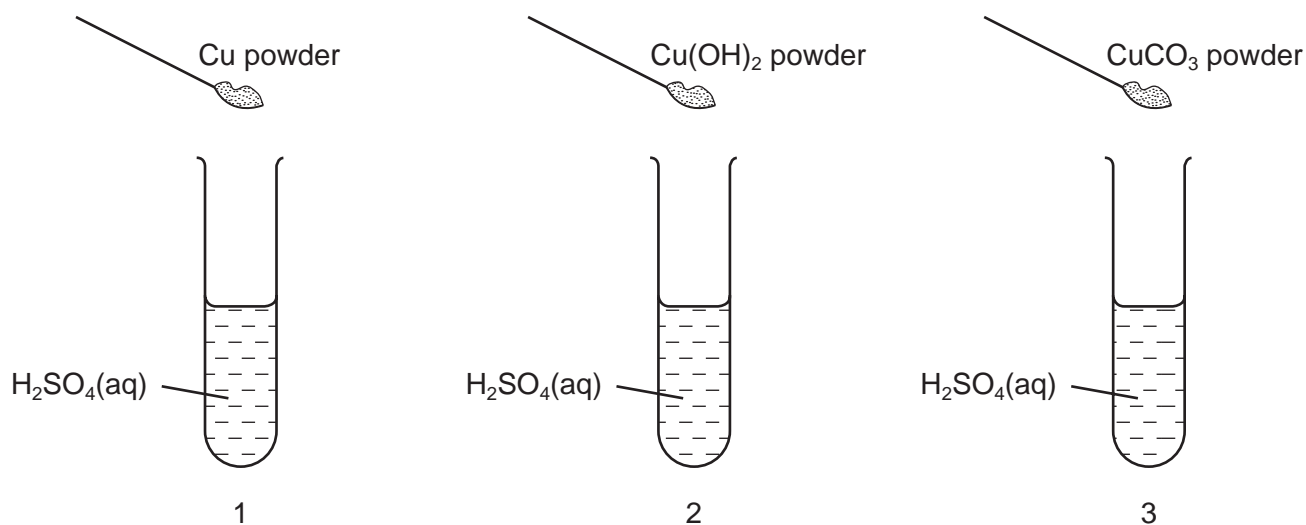

The mixtures are stirred.

Which test-tubes then contain Cu²⁺(aq) ions?

- A** 1 and 2 only
B 1 and 3 only
C 2 and 3 only
D 1, 2 and 3
- 20 The equation shows the reaction between a halogen and aqueous bromide ions.

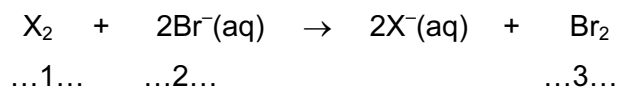

Which words should be written in gaps 1, 2 and 3?

	1	2	3
A	chlorine	brown	colourless
B	chlorine	colourless	brown
C	iodine	brown	colourless
D	iodine	colourless	brown

21 The diagram shows an outline of part of the Periodic Table.

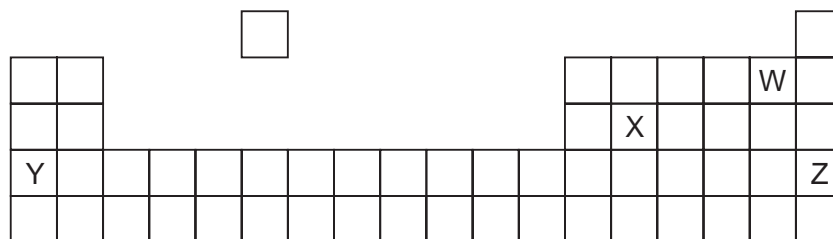

Which two elements could form a covalent compound?

- A** W and X **B** W and Y **C** X and Y **D** X and Z

22 A student is asked to complete two sentences.

Metallic and non-metallic elements are classified in the1..... This can be used to2..... the properties of elements.

Which words correctly complete the gaps?

	gap 1	gap 2
A	Periodic Table	measure
B	Periodic Table	predict
C	reactivity series	measure
D	reactivity series	predict

23 The diagram shows three balloons held by children.



Which of the balloons float up into the air when the children let go?

- A** P only
B P and R only
C Q only
D Q and R only

24 Three mixtures are made.

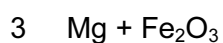
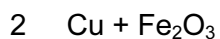
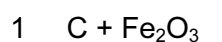

The mixtures are heated strongly.

Which of the elements C, Cu and Mg are reactive enough to reduce the iron oxide to iron?

- A C and Cu only
- B C and Mg only
- C Cu and Mg only
- D C, Cu and Mg

25 Which property do **all** metals have?

- A Their densities are low.
- B Their melting points are high.
- C They act as catalysts.
- D They conduct electricity.

26 Copper, iron and zinc are all used to make things.

Which of these three metals are also used in the form of alloys?

	copper	iron	zinc
A	✓	✓	✓
B	✓	✓	x
C	x	✓	✓
D	x	x	✓

27 Which diagram shows a common use of stainless steel?

A

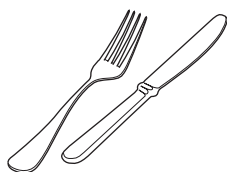

B



C

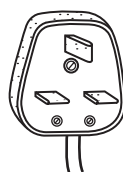

D

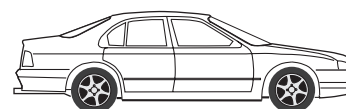

28 The diagram shows stages in the purification of water.

Which stage uses chlorine?

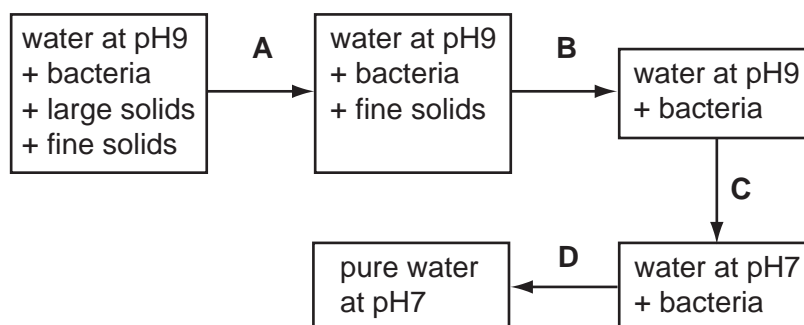

29 In experiments on rusting, some students are each given two metal objects to study.

One student set up his apparatus as shown.

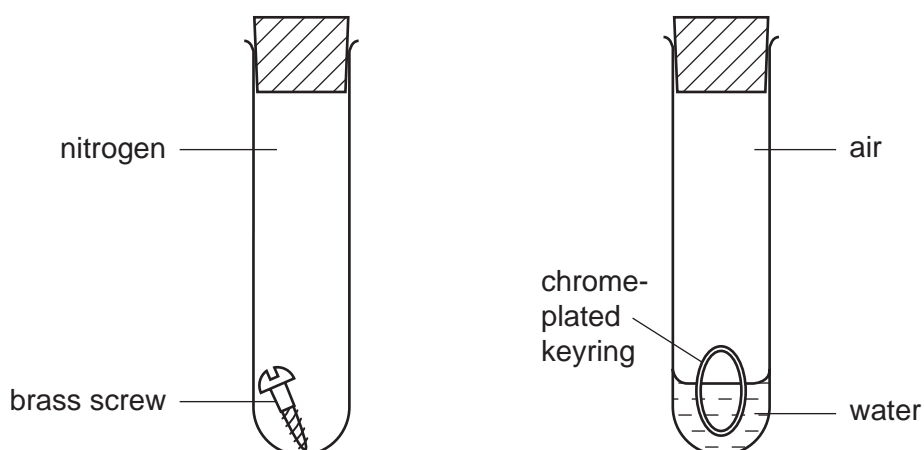

Which objects rusted?

	brass screw	chrome-plated keyring
A	✓	✓
B	✓	x
C	x	✓
D	x	x

30 Which substance is **not** a pollutant of clean air?

- A** argon
- B** carbon monoxide
- C** nitrogen dioxide
- D** sulphur dioxide

31 Which metallic element is needed in a complete fertiliser?

- A calcium
- B magnesium
- C potassium
- D sodium

32 A newspaper article claims that carbon dioxide is formed as follows.

- 1 during respiration
- 2 when calcium carbonate reacts with hydrochloric acid
- 3 when methane burns in air

Which statements are correct?

- A 1, 2 and 3
- B 1 and 2 only
- C 1 and 3 only
- D 2 and 3 only

33 The diagram shows an experiment.

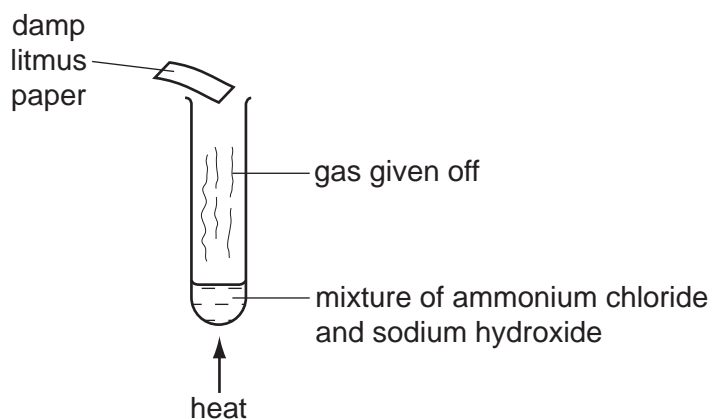

What is the name of the gas and the final colour of the litmus paper?

	gas	colour
A	ammonia	blue
B	ammonia	red
C	chlorine	white
D	chlorine	red

34 The diagram shows the pH values of the soil in **X** and **Y**, two parts of the garden of a house.

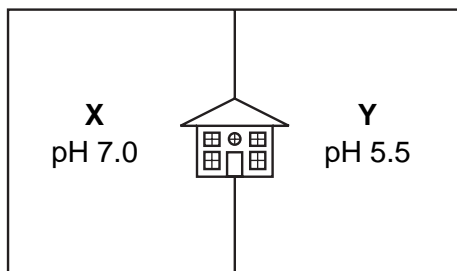

The house owner wishes to use lime to neutralise the soil in one part of the garden.

To which part should the lime be added, and why?

	part of garden	because lime is
A	X	acidic
B	X	basic
C	Y	acidic
D	Y	basic

35 In the molecule shown, the two -OH groups are numbered.

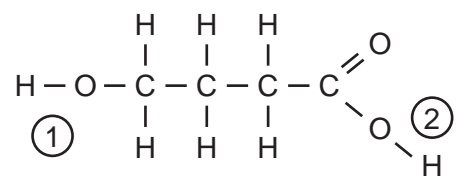

Which of these -OH groups react with aqueous sodium hydroxide?

	$\textcircled{1}$	$\textcircled{2}$
A	✓	✓
B	✓	x
C	x	✓
D	x	x

36 When a suitable catalyst is used, ethene reacts with steam.

What is the structure of the compound formed?

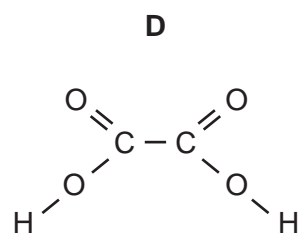
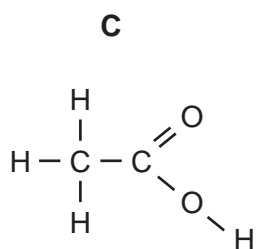
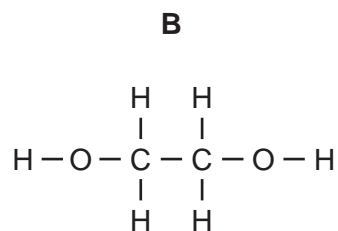
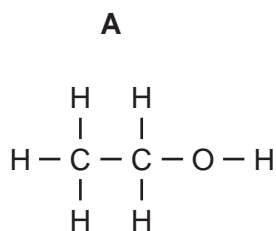

37 The diagram shows the separation of crude oil into fractions.

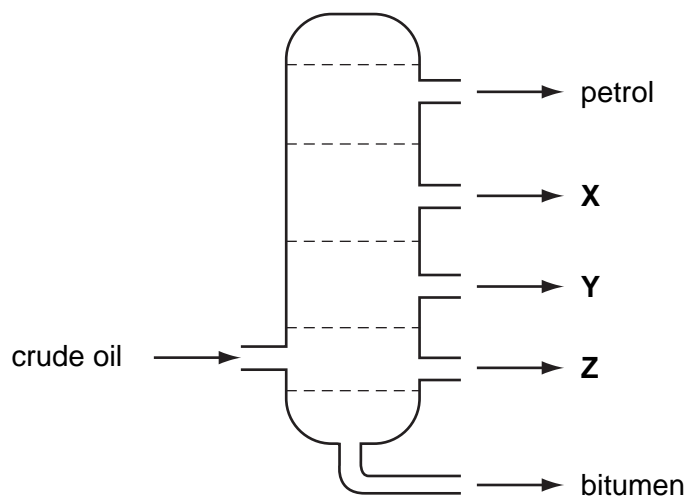

What could **X**, **Y** and **Z** represent?

	X	Y	Z
A	diesel	lubricating oil	paraffin
B	lubricating oil	diesel	paraffin
C	lubricating oil	paraffin	diesel
D	paraffin	diesel	lubricating oil

38 Which of the compounds shown are used as fuels?

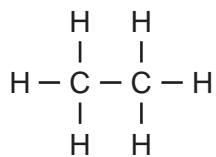

1

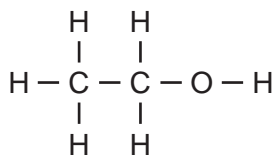

2

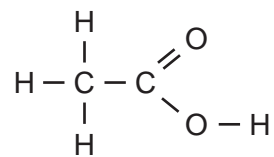

3

	1	2	3
A	✓	✓	✓
B	✓	✓	x
C	✓	x	✓
D	x	✓	✓

39 Which set of diagrams shows three substances that are all in the same homologous series?

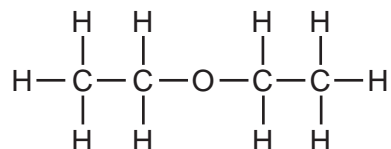
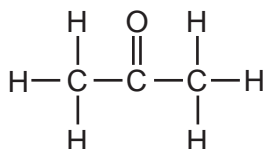
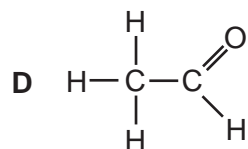
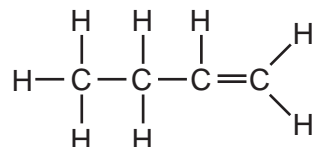
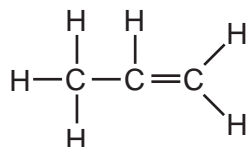
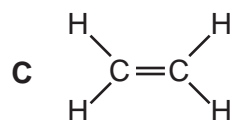
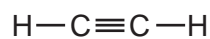
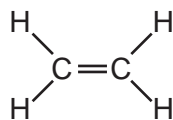
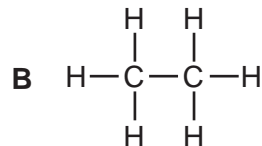
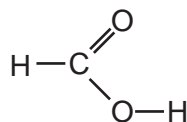
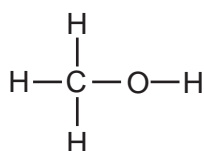
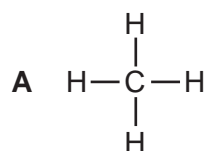

40 The diagram shows the structure of a small molecule.

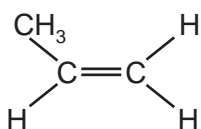

Which chain-like molecule is formed when these small molecules link together?

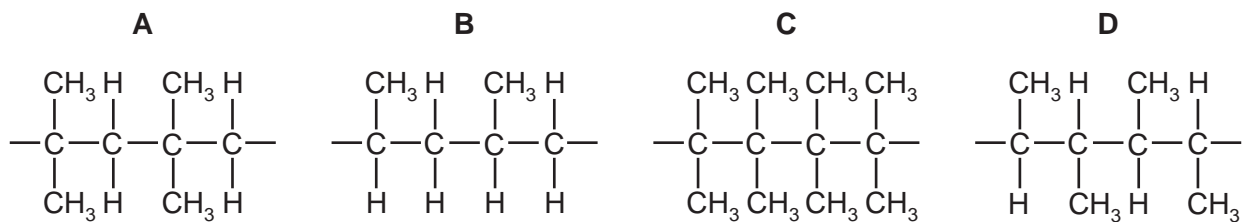

BLANK PAGE

BLANK PAGE

DATA SHEET
The Periodic Table of the Elements

		Group																																	
		I	II	III	IV	V	VI	VII	0																										
7	Li Lithium 3	9	Be Beryllium 4											4	He Helium 2																				
23	Na Sodium 11	24	Mg Magnesium 12											19	F Fluorine 9																				
39	K Potassium 19	40	Ca Calcium 20	51	V Vanadium 23	52	Cr Chromium 24	55	Mn Manganese 25	56	Fe Iron 26	59	Co Cobalt 27	64	Cu Copper 29	70	Ga Gallium 31	73	Ge Germanium 32	75	As Arsenic 33	79	Se Selenium 34	80	Br Bromine 35	84	Kr Krypton 36								
85	Rb Rubidium 37	88	Sr Strontium 38	91	Zr Zirconium 40	96	Mo Molybdenum 42	101	Ru Ruthenium 44	106	Pd Palladium 46	112	Cd Cadmium 48	115	In Indium 49	122	Sb Antimony 51	128	Te Tellurium 52	131	Xe Xenon 54														
133	Cs Caesium 55	137	Ba Barium 56	178	Hf Hafnium 72	184	W Tungsten 74	190	Os Osmium 76	195	Pt Platinum 78	201	Hg Mercury 80	204	Tl Thallium 81	209	Pb Lead 82	207	Pb Lead 82	209	Bi Bismuth 83	210	Po Polonium 84	210	Po Polonium 84	210	Rn Radon 86								
226	Ra Radium 88	227	Ac Actinium 89											140	Ce Cerium 58	141	Pr Praseodymium 59	144	Nd Neodymium 60	150	Sm Samarium 62	152	Eu Europium 63	157	Gd Gadolinium 64	162	Dy Dysprosium 66	165	Ho Holmium 67	169	Tm Thulium 69	173	Yb Ytterbium 70	175	Lu Lutetium 71
87	Fr Francium	90	Th Thorium	91	Pa Protactinium	92	U Uranium	93	Np Neptunium	94	Pu Plutonium	95	Am Americium	96	Cm Curium	97	Bk Berkelium	98	Cf Californium	99	Es Einsteinium	100	Fm Fermium	101	Md Mendelevium	102	No Nobelium	103	Lr Lawrencium						

* 58-71 Lanthanoid series
† 90-103 Actinoid series

a	X
b	

a = relative atomic mass
X = atomic symbol
b = proton (atomic) number

The volume of one mole of any gas is 24 dm³ at room temperature and pressure (r.t.p.).

Permission to reproduce items where third-party owned material protected by copyright is included has been sought and cleared where possible. Every reasonable effort has been made by the publisher (UCLES) to trace copyright holders, but if any items requiring clearance have unwittingly been included, the publisher will be pleased to make amends at the earliest possible opportunity.

University of Cambridge International Examinations is part of the University of Cambridge Local Examinations Syndicate (UCLES), which is itself a department of the University of Cambridge.