



UNIVERSITY OF CAMBRIDGE INTERNATIONAL EXAMINATIONS
International General Certificate of Secondary Education

CANDIDATE
NAME

CENTRE
NUMBER

| | | | |
|--|--|--|--|
| | | | |
|--|--|--|--|

CANDIDATE
NUMBER

| | | | |
|--|--|--|--|
| | | | |
|--|--|--|--|

* 2 2 9 2 5 2 6 8 1 0 *

BIOLOGY

0610/61

Paper 6 Alternative to Practical

October/November 2010

1 hour

Candidates answer on the Question Paper

No Additional Materials are required.

READ THESE INSTRUCTIONS FIRST

Write your Centre number, candidate number and name on all the work you hand in.

Write in dark blue or black pen.

You may use a pencil for any diagrams or graphs.

Do not use staples, paper clips, highlighters, glue or correction fluid.

DO NOT WRITE IN ANY BARCODES.

Answer **all** questions.

At the end of the examination, fasten all your work securely together.

The number of marks is given in brackets [] at the end of each question or part question.

| For Examiner's Use | |
|--------------------|--|
| 1 | |
| 2 | |
| 3 | |
| Total | |

This document consists of **9** printed pages and **3** blank pages.



- 1 Enzymes are used commercially to extract fruit juices. The use of enzymes increases the volume of juice produced.

An investigation was carried out to determine the volume of apple juice produced at different temperatures.

Mixtures of apple pulp and enzyme were left for 15 minutes at different temperatures.

After 15 minutes, the mixtures were filtered and the juice collected.

Fig.1.1 shows the volume of juice collected from each mixture.

- (a) (i) Record the volume of juice in each measuring cylinder in Table 1.1.

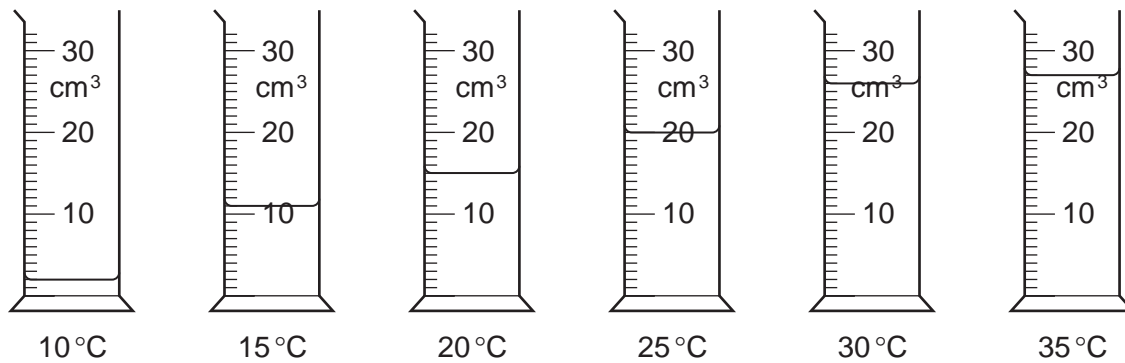

Fig. 1.1.

Table 1.1

| temperature / °C | volume of juice collected / cm ³ |
|------------------|---|
| 10 | |
| 15 | |
| 20 | |
| 25 | |
| 30 | |
| 35 | |

[3]

(ii) Present the data in a suitable graphical form.

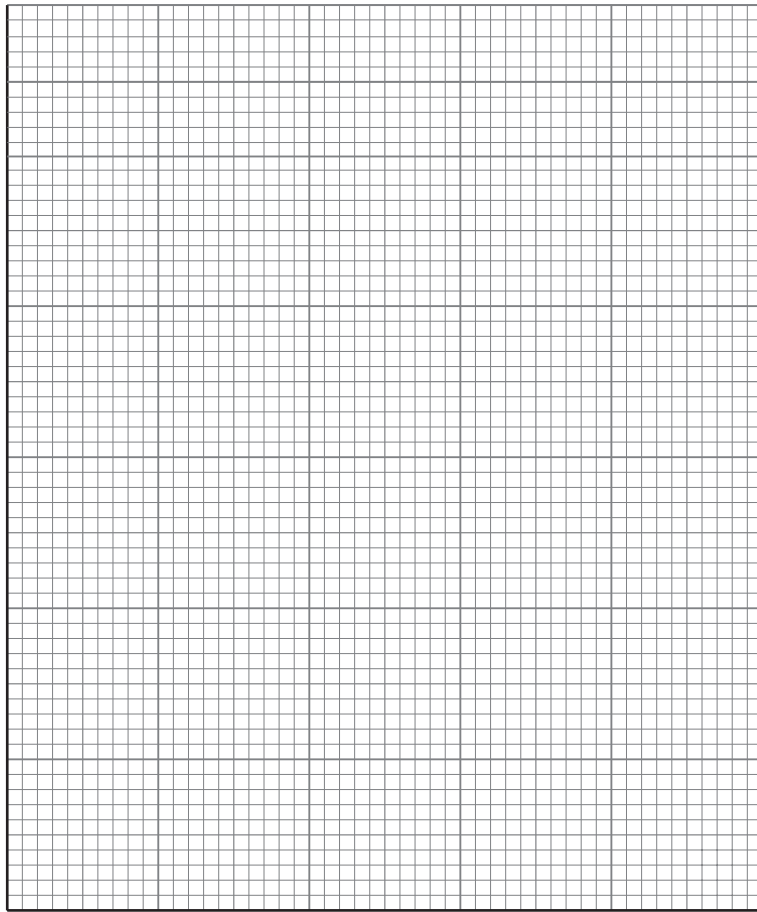

For
Examiner's
Use

[5]

(iii) Describe the results.

.....

.....

.....

.....

.....

.....

.....

[2]

(b) Describe an investigation to show the effect of pH on the activity of the enzyme that is used to extract apple juice.

*For
Examiner's
Use*

.....

.....

.....

.....

.....

.....

.....

.....

.....

.....

.....

..... [6]

[Total : 16]

2 Fig. 2.1 shows a honey bee, *Apis mellifera*.



Fig. 2.1

(a) Make a labelled drawing of the back leg of the honey bee shown in Fig. 2.1.

For
Examiner's
Use

[5]

Honey bees are important in pollination when they gather nectar from flowers.
 The nectar is used for making honey.
 Honey contains pollen grains which identify the flowers that the nectar was gathered from.

For
 Examiner's
 Use

Fig. 2.2 shows some pollen grains in a sample of honey as seen with a microscope.

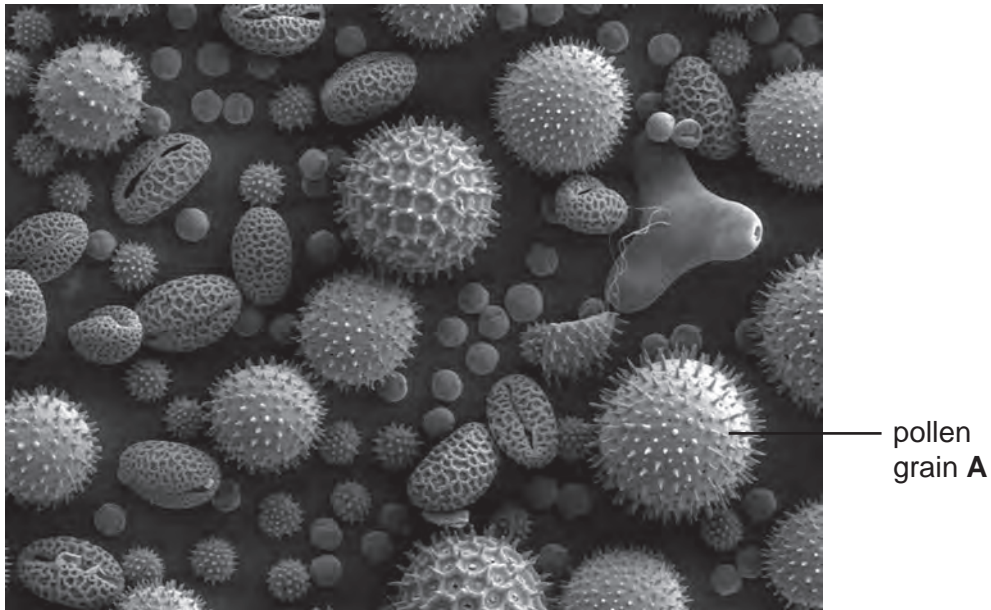

× 500

Fig. 2.2

(b) (i) Measure the diameter of pollen grain **A**. Draw a line on Fig. 2.2 to show where you have made your measurement.

diameter of pollen grain **A** in Fig. 2.2 mm [1]

(ii) Calculate the actual diameter of pollen grain **A**. Show your working.

actual diameter of pollen grain **A** mm [2]

(c) Describe how you could safely test a sample of honey for starch and reducing sugar:

.....

.....

.....

.....

..... [4]

Honey production has been affected by parasites found on both the adult and larval stages of honey bees.

One of the latest pests has been identified as a blood sucking parasite, *Varroa destructor*.

Fig. 2.3 shows the external appearance of this parasite.



× 60

Fig. 2.3

(d) (i) *Varroa* is a parasite. Using the information above, suggest the meaning of the term parasite.

.....

.....

..... [2]

(ii) Name the arthropod groups to which the honey bee, *Apis mellifera*, and the parasite, *Varroa destructor*, belong. For each organism, give one feature which leads to your identification.

| organism | arthropod group | feature |
|--|-----------------|----------------|
| honey bee (<i>Apis mellifera</i>) | | |
| parasite (<i>Varroa destructor</i>) | | |

[4]

[Total : 18]

For
Examiner's
Use

3 There is variation in the shape of human thumbs.

For
Examiner's
Use

Fig. 3.1 shows the two forms referred to as 'straight' and 'hitch hikers'.

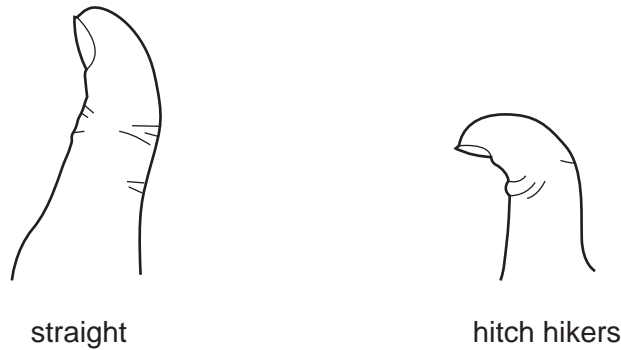

Fig. 3.1

A survey of thumb shape was carried out on 197 students. The results are shown in Table 3.1.

Table 3.1

| age / years | number of students with 'straight' thumbs | | number of students with 'hitch hiker' thumbs | |
|-------------|---|--------|--|--------|
| | male | female | male | female |
| 12 | 21 | 24 | 4 | 2 |
| 13 | 18 | 28 | 3 | 5 |
| 14 | 19 | 15 | 2 | 3 |
| 15 | 26 | 20 | 3 | 4 |
| total | 84 | 87 | 12 | 14 |

(a) Describe the results shown in Table 3.1.

.....

.....

.....

.....

..... [3]

(b) Scientists think that thumb shape is controlled by a single gene.

What evidence is there from Table 3.1 to support this idea?

.....

.....

..... [3]

[Total : 6]

*For
Examiner's
Use*

Copyright Acknowledgements:

Question 2 Figure 2.2 © <http://autopollen.massey.ac.nz>; pollen

Permission to reproduce items where third-party owned material protected by copyright is included has been sought and cleared where possible. Every reasonable effort has been made by the publisher (UCLES) to trace copyright holders, but if any items requiring clearance have unwittingly been included, the publisher will be pleased to make amends at the earliest possible opportunity.

University of Cambridge International Examinations is part of the Cambridge Assessment Group. Cambridge Assessment is the brand name of University of Cambridge Local Examinations Syndicate (UCLES), which is itself a department of the University of Cambridge.