

Write your name here

Surname	Other names
---------	-------------

<b>Pearson Edexcel</b> <b>Level 1/Level 2 GCSE (9 - 1)</b>	Centre Number <input style="width: 20px; height: 20px;" type="text"/> <input style="width: 20px; height: 20px;" type="text"/> <input style="width: 20px; height: 20px;" type="text"/> <input style="width: 20px; height: 20px;" type="text"/>	Candidate Number <input style="width: 20px; height: 20px;" type="text"/> <input style="width: 20px; height: 20px;" type="text"/> <input style="width: 20px; height: 20px;" type="text"/> <input style="width: 20px; height: 20px;" type="text"/>
---	--	---

# Combined Science

## Paper 2: Biology 2

Foundation Tier

Monday 11 June 2018 – Morning <b>Time: 1 hour 10 minutes</b>	Paper Reference <b>1SC0/2BF</b>
---	------------------------------------

<b>You must have:</b> Calculator, ruler	Total Marks <input style="width: 100%; height: 40px;" type="text"/>
--	--

### Instructions

- Use **black** ink or ball-point pen.
- **Fill in the boxes** at the top of this page with your name, centre number and candidate number.
- Answer **all** questions.
- Answer the questions in the spaces provided  
– *there may be more space than you need.*
- Calculators may be used.
- Any diagrams may NOT be accurately drawn, unless otherwise indicated.
- You must **show all your working out** with **your answer clearly identified** at the **end of your solution**.

### Information

- The total mark for this paper is 60.
- The marks for **each** question are shown in brackets  
– *use this as a guide as to how much time to spend on each question.*
- In questions marked with an **asterisk (\*)**, marks will be awarded for your ability to structure your answer logically showing how the points that you make are related or follow on from each other where appropriate.

### Advice

- Read each question carefully before you start to answer it.
- Try to answer every question.
- Check your answers if you have time at the end.

*Turn over* ►

P59180A

©2018 Pearson Education Ltd.

1/



Answer ALL questions. Write your answers in the spaces provided.

Some questions must be answered with a cross in a box ☒.  
If you change your mind about an answer, put a line through the box ☒ and then mark your new answer with a cross ☒.

1 Insulin is produced by an endocrine gland and is transported in the blood.

(a) (i) Which row shows the endocrine gland and the target organs for insulin?

(1)

	endocrine gland	target organs
<input type="checkbox"/> A	adrenal	liver and muscles
<input type="checkbox"/> B	adrenal	small and large intestines
<input type="checkbox"/> C	pancreas	liver and muscles
<input type="checkbox"/> D	pancreas	small and large intestines

(ii) Which part of the blood transports insulin to its target organs?

(1)

- A plasma
- B red blood cells
- C white blood cells
- D platelets

DO NOT WRITE IN THIS AREA

DO NOT WRITE IN THIS AREA

DO NOT WRITE IN THIS AREA

DO NOT WRITE IN THIS AREA

DO NOT WRITE IN THIS AREA

DO NOT WRITE IN THIS AREA



(b) Figure 1 shows the blood glucose and blood insulin concentration for a healthy person during one day.

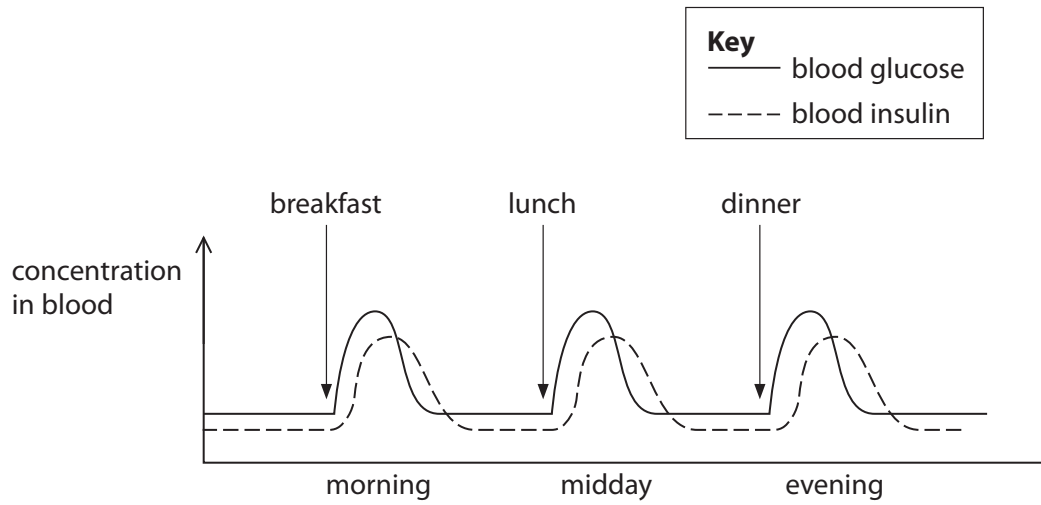

**Figure 1**

The blood glucose concentration increases after a meal.

Explain why the blood glucose concentration then decreases.

(2)

.....

.....

.....

.....

.....

(c) State **one** cause of type 1 diabetes.

(1)

.....

.....



(d) Explain how controlling the diet can be used to treat type 2 diabetes.

(2)

.....

.....

.....

.....

(e) A scientist is planning to test a new treatment for type 2 diabetes.

She selects 300 volunteers who have type 2 diabetes.

State **two** other factors that the scientist should consider when selecting the 300 volunteers.

(2)

1 .....

2 .....

**(Total for Question 1 = 9 marks)**

DO NOT WRITE IN THIS AREA

DO NOT WRITE IN THIS AREA

DO NOT WRITE IN THIS AREA

DO NOT WRITE IN THIS AREA

DO NOT WRITE IN THIS AREA

DO NOT WRITE IN THIS AREA



2 (a) Figure 2 shows alveoli from a healthy lung.

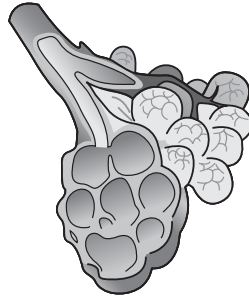

**Figure 2**

Smoking can cause a condition called emphysema.

Figure 3 shows alveoli from a person with emphysema.

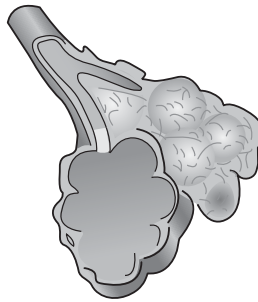

**Figure 3**

Use words from the box to complete the following sentences.

(2)

breathing	diffusion	larger
osmosis	smaller	thicker

The alveoli from the person with emphysema have a ..... surface area than the alveoli from a healthy lung.

The surface area of the alveoli will affect how much oxygen moves into the blood by the process of .....



P 5 9 1 8 0 A 0 5 2 4

(b) The graph in Figure 4 shows the volume of oxygen an athlete absorbs at different running speeds.

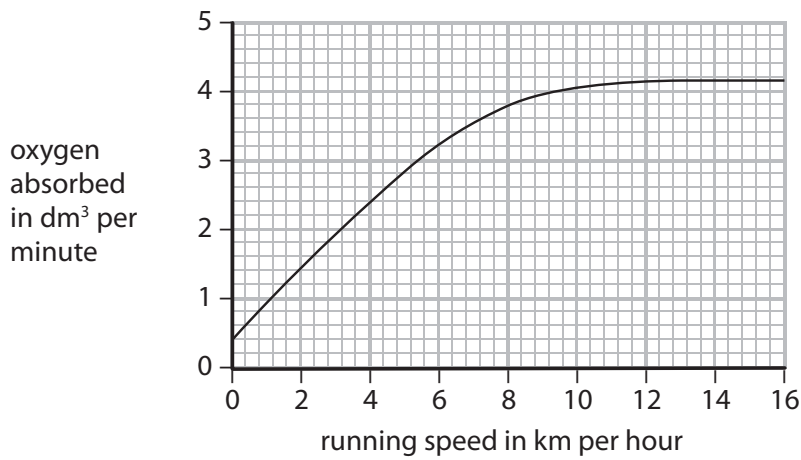

**Figure 4**

(i) Describe the trend shown in Figure 4.

(2)

.....

.....

.....

.....

DO NOT WRITE IN THIS AREA

DO NOT WRITE IN THIS AREA

DO NOT WRITE IN THIS AREA

DO NOT WRITE IN THIS AREA

DO NOT WRITE IN THIS AREA

DO NOT WRITE IN THIS AREA



(ii) Which uses more oxygen when the running speed of the athlete changes from 4 to 6 km per hour?

(1)

- A increasing aerobic respiration
- B increasing anaerobic respiration
- C decreasing aerobic respiration
- D decreasing anaerobic respiration

(iii) Explain why the athlete produces lactic acid when running at 14 km per hour.

(2)

.....

.....

.....

.....

**(Total for Question 2 = 7 marks)**



DO NOT WRITE IN THIS AREA

DO NOT WRITE IN THIS AREA

DO NOT WRITE IN THIS AREA

DO NOT WRITE IN THIS AREA

DO NOT WRITE IN THIS AREA

DO NOT WRITE IN THIS AREA

DO NOT WRITE IN THIS AREA

DO NOT WRITE IN THIS AREA

DO NOT WRITE IN THIS AREA

DO NOT WRITE IN THIS AREA

DO NOT WRITE IN THIS AREA

DO NOT WRITE IN THIS AREA

BLANK PAGE





3 (a) Plants use nitrate ions to make proteins and chlorophyll.

(i) What effects will a low nitrate ion concentration in soils have on plants?

(1)

- A reduced growth and darker green leaves
- B reduced growth and lighter green leaves
- C increased growth and darker green leaves
- D increased growth and lighter green leaves

(ii) Which organisms convert nitrogen to nitrate ions during the nitrogen cycle?

(1)

- A bacteria
- B mammals
- C fungi
- D worms



P 5 9 1 8 0 A 0 9 2 4

(b) Figure 5 shows part of a root as seen using a light microscope.

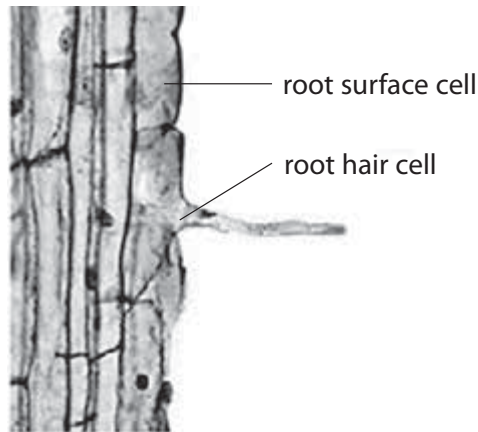

**Figure 5**

Figure 6 shows information about the two types of cell labelled in Figure 5.

type of cell	surface area in $\mu\text{m}^2$	volume in $\mu\text{m}^3$	surface area to volume ratio
root surface cell	5 000	250 000	1 : 50
root hair cell	36 000	288 000	?

**Figure 6**

(i) Calculate the surface area to volume ratio of the root hair cell.

(2)

(ii) Explain the benefit to the plant of having root hair cells.

(2)

.....

.....

.....

DO NOT WRITE IN THIS AREA

DO NOT WRITE IN THIS AREA

DO NOT WRITE IN THIS AREA

DO NOT WRITE IN THIS AREA

DO NOT WRITE IN THIS AREA

DO NOT WRITE IN THIS AREA



(c) Algae are green plants.

Figure 7 shows the number of algae in a lake in the United Kingdom during one year.

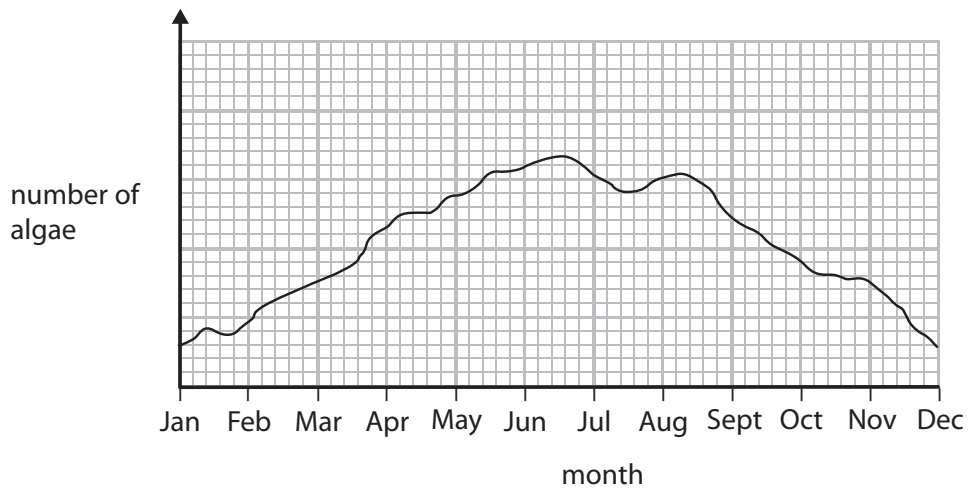

**Figure 7**

Explain the changes in the number of algae in the lake from February to June.

(3)

.....

.....

.....

.....

.....

.....

.....

.....

**(Total for Question 3 = 9 marks)**



4 Figure 8 shows a British glow-worm.

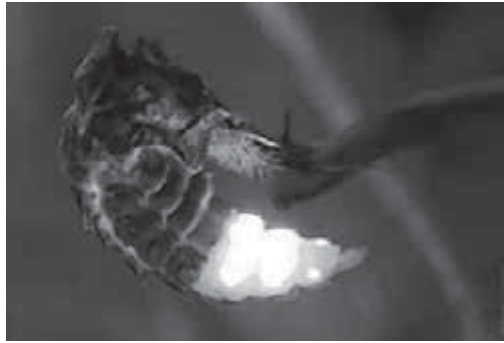

© Dom Greves Digital

**Figure 8**

**Read the following extract before answering the questions.**

Female glow-worms produce bright lights in the summer to attract males.  
Glow-worm larvae are predators of slugs and snails, but adult glow-worms do not feed.  
Females only have a few weeks to attract a mate and lay eggs, before the females die.

(a) What will happen if the population of snails decreases?

(1)

- A the population of glow-worms will increase
- B adult glow-worms will eat more snails
- C glow-worm larvae will eat more slugs
- D adult female glow-worms will glow more brightly

DO NOT WRITE IN THIS AREA

DO NOT WRITE IN THIS AREA

DO NOT WRITE IN THIS AREA

DO NOT WRITE IN THIS AREA

DO NOT WRITE IN THIS AREA

DO NOT WRITE IN THIS AREA



(b) Female glow-worms have an enzyme called luciferase.

The glow is produced when this enzyme catalyses a reaction between oxygen and a protein.

A scientist devised a plan to investigate the effect of oxygen concentration on this reaction.

The scientist had:

- five flasks of water each with a different concentration of dissolved oxygen
- a solution of the protein
- a solution of the enzyme.

The first step of this plan is:

Step 1. Add some of the protein solution to each of the five flasks.

(i) Describe the next **two** steps that should be in this plan to obtain results for this investigation.

(2)

Step 2 .....

.....

Step 3 .....

.....

(ii) Which procedure would improve the investigation?

(1)

- A** change the concentration of the protein solution in each flask
- B** change the volume of the protein solution added to each flask
- C** keep the concentration of dissolved oxygen the same in each flask
- D** keep the volume of each solution the same in each flask



(iii) The enzyme luciferase works best at pH8.

Explain why the activity of the enzyme decreases at pH5.

(2)

.....

.....

.....

.....

(c) Female glow-worms are found attached to grass plants in a large field.

(i) Describe a sampling technique to find the **mean** number of female glow-worms in 1 m<sup>2</sup> of the field.

(3)

.....

.....

.....

.....

.....

(ii) The mean number of female glow-worms in 1 m<sup>2</sup> of the field is 5.

The field has a total area of 800 m<sup>2</sup>.

Estimate the number of female glow-worms in the whole field.

(1)

.....

**(Total for Question 4 = 10 marks)**

DO NOT WRITE IN THIS AREA

DO NOT WRITE IN THIS AREA

DO NOT WRITE IN THIS AREA

DO NOT WRITE IN THIS AREA

DO NOT WRITE IN THIS AREA

DO NOT WRITE IN THIS AREA



5 (a) Figure 9 shows a diagram of a red blood cell from a turtle and a diagram of a red blood cell from a human.

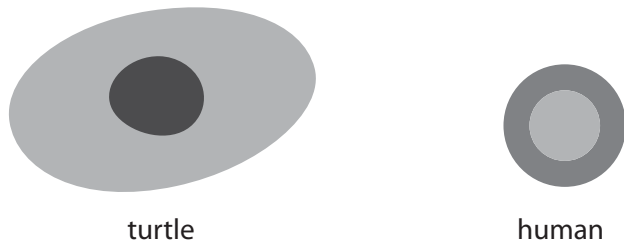

Figure 9

(i) These cells are animal cells.

Animal cells do not have

(1)

- A cytoplasm
- B a cell membrane
- C a cell wall
- D mitochondria

(ii) The actual length of the red blood cell from a turtle is  $20.5 \mu\text{m}$ .

Calculate the length of the magnified image of the red blood cell of the turtle when magnified  $400\times$ .

(2)

..... $\mu\text{m}$

(iii) The width of the human red blood cell, when magnified  $400\times$ , is  $3.08 \text{ mm}$ .

Calculate the actual width of the cell and show your answer in standard form.

(2)

..... $\text{mm}$



DO NOT WRITE IN THIS AREA

DO NOT WRITE IN THIS AREA

DO NOT WRITE IN THIS AREA

DO NOT WRITE IN THIS AREA

DO NOT WRITE IN THIS AREA

DO NOT WRITE IN THIS AREA

(b) Red blood cells are carried in veins and arteries.

Figure 10 shows the equipment used to measure the elasticity of an artery.

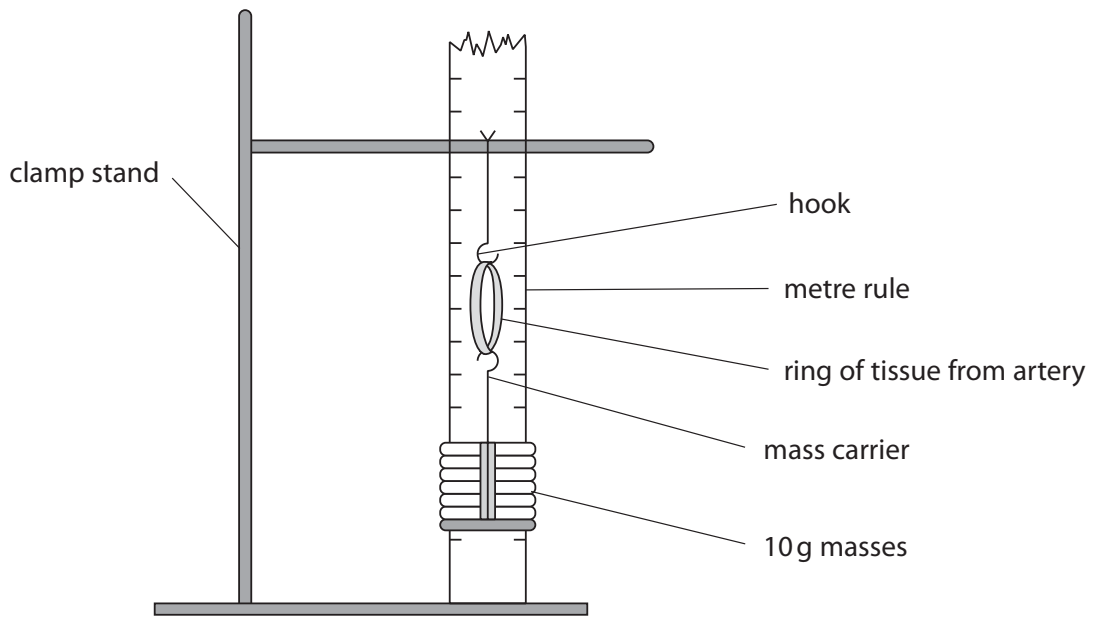

**Figure 10**

(i) Describe a method you could use to see how much the ring of tissue from an artery could stretch before it no longer returned to its original size.

(3)

.....

.....

.....

.....

.....

.....

.....

(ii) Give **one** safety precaution you need to take when handling animal tissue such as blood vessels.

(1)

.....

.....

DO NOT WRITE IN THIS AREA

DO NOT WRITE IN THIS AREA

DO NOT WRITE IN THIS AREA

DO NOT WRITE IN THIS AREA

DO NOT WRITE IN THIS AREA

DO NOT WRITE IN THIS AREA





(c) Figure 11 shows the circulatory system of a frog.

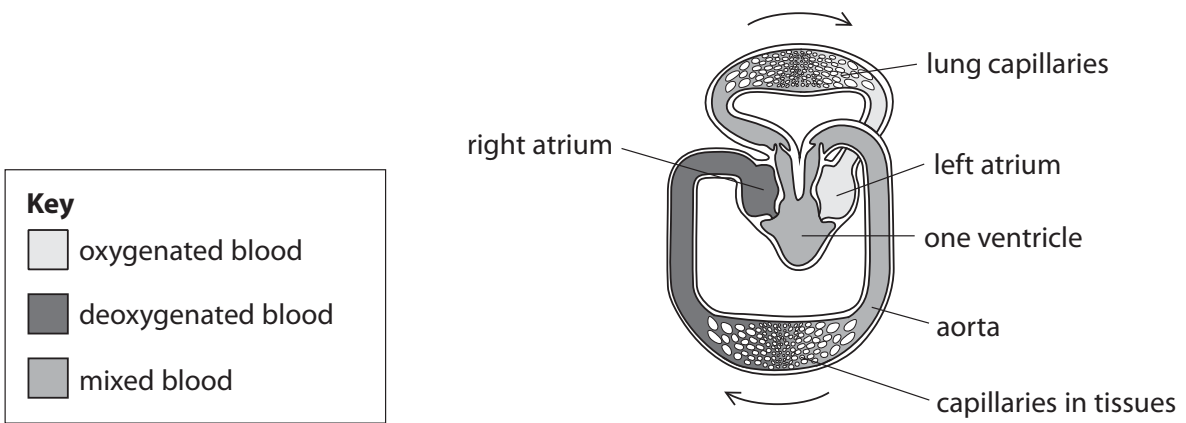

**Figure 11**

Explain why the circulatory system of a frog is less efficient at carrying oxygen to the tissues than the circulatory system of a human.

(3)

.....

.....

.....

.....

.....

.....

.....

.....

.....

.....

.....

**(Total for Question 5 = 12 marks)**



- 6 A student compared the number of stomata on the upper and lower surfaces of a leaf. She completed a leaf peel as shown in Figure 12.

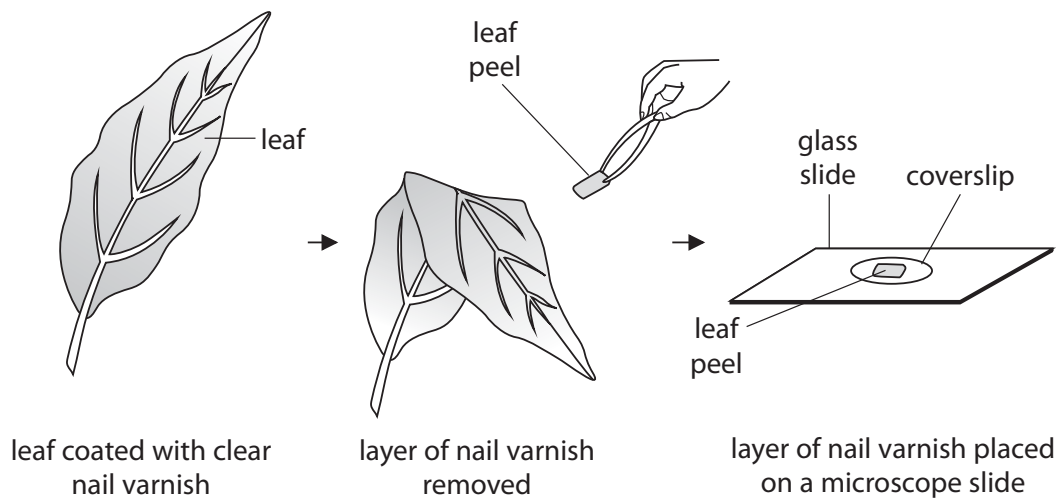

**Figure 12**

The layer of nail varnish shows an impression of the cells on the surface of the leaf.

- (a) (i) State why a coverslip is placed on top of the leaf peel.

(1)

- (ii) Explain why the leaf peel rather than the whole leaf was viewed with a microscope.

(2)



(b) The student drew a biological diagram of the leaf peel taken from the underside of the leaf.

Figure 13 shows this diagram.

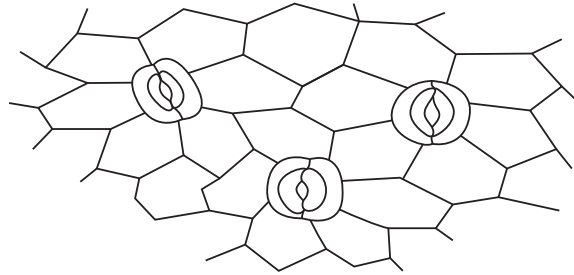

**Figure 13**

(i) State the number of stomata visible on Figure 13.

(1)

(ii) The student observed that the stomata were open.

Describe how stomata open.

(3)





DO NOT WRITE IN THIS AREA

DO NOT WRITE IN THIS AREA

DO NOT WRITE IN THIS AREA

DO NOT WRITE IN THIS AREA

DO NOT WRITE IN THIS AREA

DO NOT WRITE IN THIS AREA

(Total for Question 6 = 13 marks)

**TOTAL FOR PAPER = 60 MARKS**



DO NOT WRITE IN THIS AREA

DO NOT WRITE IN THIS AREA

DO NOT WRITE IN THIS AREA

DO NOT WRITE IN THIS AREA

DO NOT WRITE IN THIS AREA

DO NOT WRITE IN THIS AREA

**BLANK PAGE**



DO NOT WRITE IN THIS AREA

DO NOT WRITE IN THIS AREA

DO NOT WRITE IN THIS AREA

DO NOT WRITE IN THIS AREA

DO NOT WRITE IN THIS AREA

DO NOT WRITE IN THIS AREA

**BLANK PAGE**



DO NOT WRITE IN THIS AREA

DO NOT WRITE IN THIS AREA

DO NOT WRITE IN THIS AREA

**BLANK PAGE**

Every effort has been made to contact copyright holders to obtain their permission for the use of copyright material. Pearson Education Ltd. will, if notified, be happy to rectify any errors or omissions and include any such rectifications in future editions.

