

Write your name here

Surname					Other names				
Pearson Edexcel									
International									
Advanced Level									
Centre Number					Candidate Number				
<input type="text"/> <input type="text"/> <input type="text"/> <input type="text"/> <input type="text"/>					<input type="text"/> <input type="text"/> <input type="text"/> <input type="text"/> <input type="text"/>				
Physics									
Advanced									
Unit 4: Physics on the Move									
Monday 30 October 2017 – Morning						Paper Reference			
Time: 1 hour 35 minutes						WPH04/01			
You must have:								Total Marks	
Ruler								<input type="text"/>	

Instructions

- Use **black** ink or ball-point pen.
- **Fill in the boxes** at the top of this page with your name, centre number and candidate number.
- Answer **all** questions.
- Answer the questions in the spaces provided
– *there may be more space than you need.*

Information

- The total mark for this paper is 80.
- The marks for **each** question are shown in brackets
– *use this as a guide as to how much time to spend on each question.*
- Questions labelled with an **asterisk** (*) are ones where the quality of your written communication will be assessed
– *you should take particular care with your spelling, punctuation and grammar, as well as the clarity of expression, on these questions.*
- The list of data, formulae and relationships is printed at the end of this booklet.
- Candidates may use a scientific calculator.

Advice

- Read each question carefully before you start to answer it.
- Try to answer every question.
- Check your answers if you have time at the end.

Turn over ►

P50795A

©2017 Pearson Education Ltd.

1/1/1/1/1/



Pearson

SECTION A

Answer ALL questions.

For questions 1–10, in Section A, select one answer from A to D and put a cross in the box .
If you change your mind, put a line through the box and then
mark your new answer with a cross .

1 Which of the following are the base units of momentum?

- A kgms^{-1}
- B kgms^{-2}
- C Ns
- D Ns^{-1}

(Total for Question 1 = 1 mark)

2 A linac is a particle accelerator. It consists of drift tubes with potential differences (p.d.) applied between them.

The drift tubes increase in length. This is so that

- A a very high accelerating p.d. can be used.
- B the accelerating p.d. used can have a constant frequency.
- C the particle acquires the same amount of energy in each tube.
- D the time spent in each tube increases as the length of each tube increases.

(Total for Question 2 = 1 mark)

3 A food mixer has a blade which completes 15 000 revolutions in a minute.

Which of the following is the angular velocity of the blade in rad s^{-1} ?

- A 40
- B 250
- C 1570
- D 94200

(Total for Question 3 = 1 mark)

DO NOT WRITE IN THIS AREA

DO NOT WRITE IN THIS AREA

DO NOT WRITE IN THIS AREA

DO NOT WRITE IN THIS AREA

DO NOT WRITE IN THIS AREA

DO NOT WRITE IN THIS AREA



4 The de Broglie wavelength associated with electrons used to study crystal structure is 2.8×10^{-10} m.

Which of the following is the speed of the electrons?

mass of electron = 9.11×10^{-31} kg

- A $3.8 \times 10^{-7} \text{ m s}^{-1}$
- B $7.4 \times 10^{-4} \text{ m s}^{-1}$
- C $1.4 \times 10^3 \text{ m s}^{-1}$
- D $2.6 \times 10^6 \text{ m s}^{-1}$

(Total for Question 4 = 1 mark)

5 A square coil of side length l has N turns. Its plane is parallel to a magnetic field of magnetic flux density B .

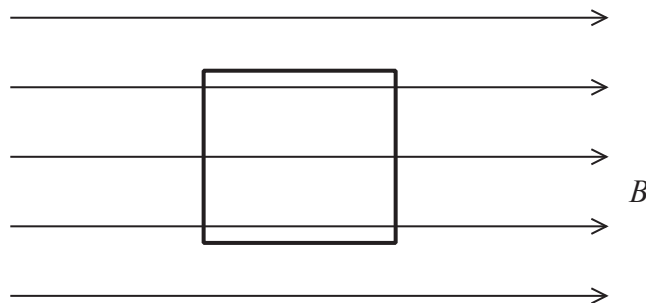

Which of the following is the flux linkage with this coil?

- A 0
- B B
- C NB
- D NBl^2

(Total for Question 5 = 1 mark)

6 A particle accelerator produces a beam of very high energy protons.

Which of the following statements describes the speed of a proton as it passes through the accelerator?

- A It increases uniformly.
- B It never reaches the speed of light.
- C It stops increasing when it reaches the speed of light.
- D It reduces as it approaches the speed of light.

(Total for Question 6 = 1 mark)



- 7 A particle Y has kinetic energy E and momentum p . A second particle Z of the same mass as Y has momentum $2p$.

Which of the following is the kinetic energy of Z?

- A $4E$
 B $2E$
 C E
 D $\frac{E}{2}$

(Total for Question 7 = 1 mark)

- 8 A resultant force of 10N acts on a particle of mass 0.2 kg for 30s. The particle is initially at rest.

Which of the following expressions gives the velocity in ms^{-1} of this particle after 30s?

- A $\frac{10 \times 0.2}{30}$
 B $\frac{10 \times 30}{0.2}$
 C $\frac{0.2 \times 30}{10}$
 D $0.2 \times 30 \times 10$

(Total for Question 8 = 1 mark)

- 9 Which of the following is the name of the process by which electrons are released from a heated filament?

- A ionisation
 B photoelectric effect
 C relativistic effect
 D thermionic emission

(Total for Question 9 = 1 mark)

DO NOT WRITE IN THIS AREA

DO NOT WRITE IN THIS AREA

DO NOT WRITE IN THIS AREA

DO NOT WRITE IN THIS AREA

DO NOT WRITE IN THIS AREA

DO NOT WRITE IN THIS AREA



10 A car, mass m , drives over a circular humpback bridge of radius r with a constant speed v .

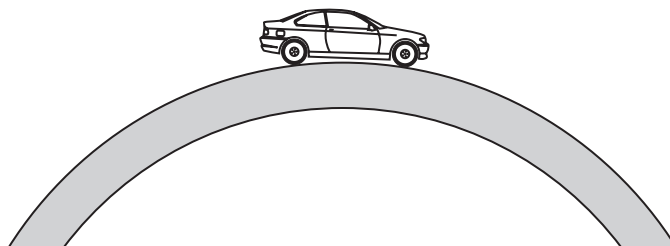

When it is at the top of the bridge, the magnitude of the force exerted on the car by the bridge is given by

- A mg
- B $\frac{mv^2}{r} + mg$
- C $\frac{mv^2}{r} - mg$
- D $mg - \frac{mv^2}{r}$

(Total for Question 10 = 1 mark)

TOTAL FOR SECTION A = 10 MARKS



P 5 0 7 9 5 A 0 5 2 4

SECTION B

Answer ALL questions in the spaces provided.

11 A plane is flying at a constant velocity, as shown.

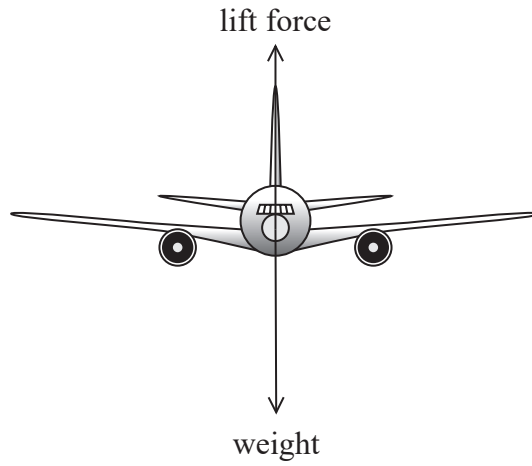

The pilot banks the plane and the lift force L is now inclined at an angle θ to the vertical.

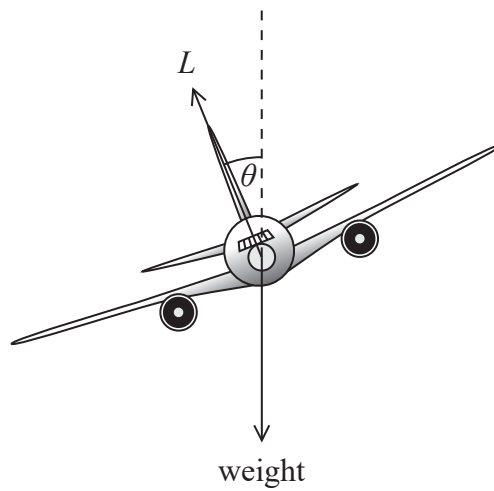

(a) Explain why this will result in circular motion.

(2)

.....

.....

.....

.....

.....

DO NOT WRITE IN THIS AREA

DO NOT WRITE IN THIS AREA

DO NOT WRITE IN THIS AREA

DO NOT WRITE IN THIS AREA

DO NOT WRITE IN THIS AREA

DO NOT WRITE IN THIS AREA



(b) The plane continues to fly with a constant speed v .

The angle θ is given by

$$\tan \theta = \frac{v^2}{rg}$$

where r is the radius of the circular path.

(i) Show that this equation is correct.

(3)

.....

.....

.....

.....

.....

.....

.....

.....

(ii) Calculate the radius of the circular path.

(2)

$$v = 150 \text{ ms}^{-1}$$
$$\theta = 10^\circ$$

.....

.....

.....

.....

.....

.....

.....

.....

Radius =

(Total for Question 11 = 7 marks)

DO NOT WRITE IN THIS AREA

DO NOT WRITE IN THIS AREA

DO NOT WRITE IN THIS AREA

DO NOT WRITE IN THIS AREA

DO NOT WRITE IN THIS AREA

DO NOT WRITE IN THIS AREA



(c) Scientists studying antimatter recently observed the creation of an anti-helium 4 nucleus, which consists of two anti-protons and two anti-neutrons.

The diagram represents the path of a proton through a magnetic field starting at point A.

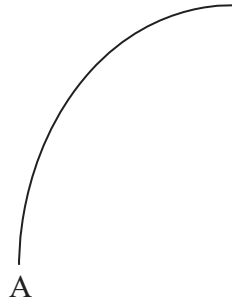

Add to the diagram the path of an anti-helium 4 nucleus also starting at point A and initially travelling with the same velocity as the proton.

Explain any differences between the paths.

(4)

.....

.....

.....

.....

.....

.....

.....

.....

.....

.....

(Total for Question 12 = 10 marks)



13 A student carries out an experiment to charge a capacitor through a resistor. She intends to measure the current during this process.

(a) (i) Draw a circuit that she could use.

(2)

(ii) Sketch a graph to indicate how the current will vary with time from when the capacitor starts to charge.

(2)

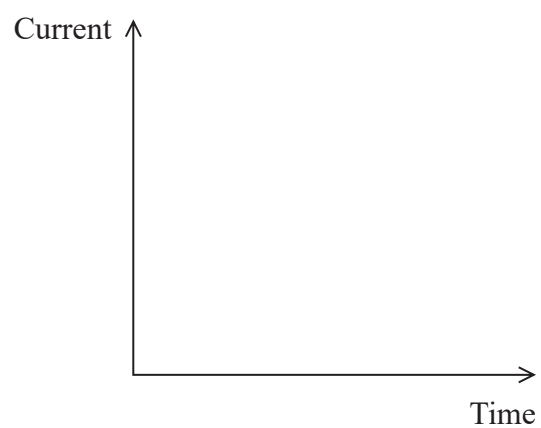

DO NOT WRITE IN THIS AREA

DO NOT WRITE IN THIS AREA

DO NOT WRITE IN THIS AREA

DO NOT WRITE IN THIS AREA

DO NOT WRITE IN THIS AREA

DO NOT WRITE IN THIS AREA



- (b) Once the capacitor is fully charged, the student discharges it through a $1.0 \text{ k}\Omega$ resistor. She measures the potential difference V across the capacitor during this process.

The graph below shows the variation of V with time t .

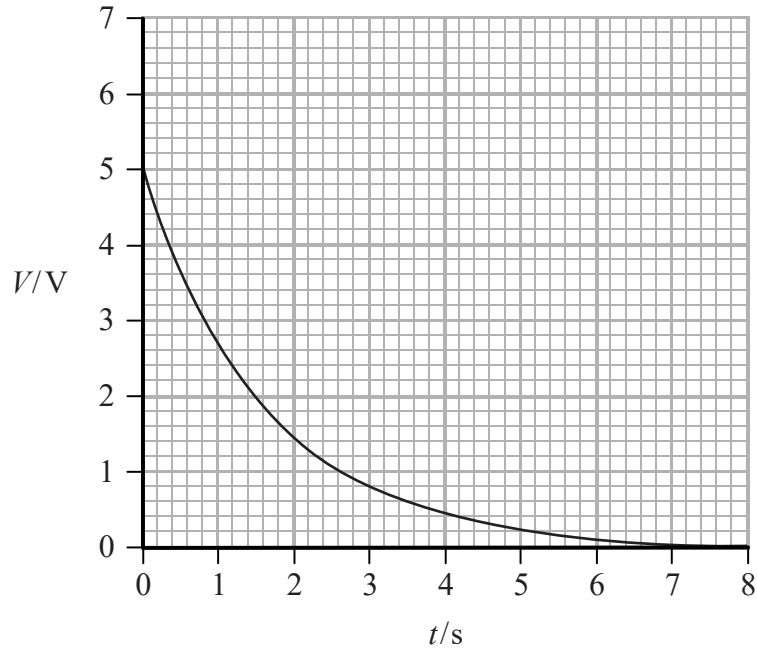

Show that the capacitance of the capacitor is about 2 mF .

(3)

.....

.....

.....

.....

.....

.....

.....



(c) Calculate the maximum energy stored on the capacitor.

(2)

.....

.....

.....

.....

Maximum energy =

(d) Another way of calculating the capacitance would be to use the results to plot a straight line graph.

Explain the graph you would plot to produce a straight line and how you would use it to calculate the capacitance of the capacitor.

(4)

.....

.....

.....

.....

.....

.....

.....

.....

.....

.....

(Total for Question 13 = 13 marks)

DO NOT WRITE IN THIS AREA

DO NOT WRITE IN THIS AREA

DO NOT WRITE IN THIS AREA

DO NOT WRITE IN THIS AREA

DO NOT WRITE IN THIS AREA

DO NOT WRITE IN THIS AREA



14 The continuous electron beam accelerator facility (CEBAF) produces very high energy electrons for particle experiments at the Jefferson Laboratory in the USA.

- (a) By the time the CEBAF has accelerated the electrons they act as if they have a mass of about 8000 times their normal (rest) mass.

Calculate the potential difference through which the electrons must be accelerated from rest to reach a mass 8000 times their rest mass.

(3)

.....

.....

.....

.....

.....

.....

.....

Potential difference =

- *(b) Electron diffraction is used to investigate the structure of nucleons.

Explain why the electrons used require very high energies.

(3)

.....

.....

.....

.....

.....

.....

.....

(Total for Question 14 = 6 marks)



15 A magnet is released so that it falls through a coil. The coil is connected to a data logger which records potential difference (p.d.).

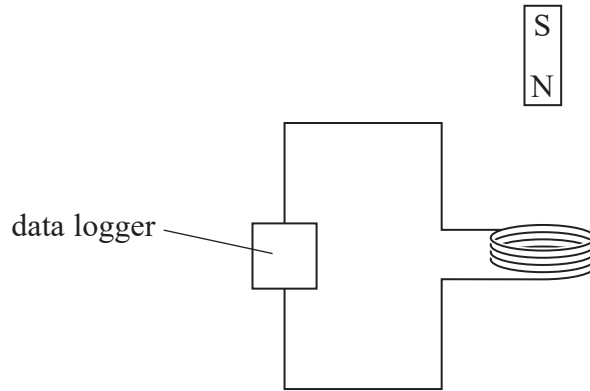

(a) Explain why the p.d. increases as the magnet approaches the coil.

(3)

.....

.....

.....

.....

.....

(b) Sketch a graph to show the variation of the p.d. with time from the moment the magnet is released until it has fallen through the coil.

(4)



(Total for Question 15 = 7 marks)

DO NOT WRITE IN THIS AREA

DO NOT WRITE IN THIS AREA

DO NOT WRITE IN THIS AREA

DO NOT WRITE IN THIS AREA

DO NOT WRITE IN THIS AREA

DO NOT WRITE IN THIS AREA



16 Experiments, supervised by Rutherford one hundred years ago, involved firing alpha particles at thin gold foil.

(a) The observations from these experiments are summarised in the table.

Complete the table with corresponding conclusions from these observations.

(3)

Observation	Conclusion
The vast majority of alpha particles go straight through without any deflection.	
A tiny proportion of the alpha particles is deflected through angles greater than 90° .	

(b) A gold nucleus has the symbol $^{197}_{79}\text{Au}$.

(i) State the meaning of these numbers.

(1)

.....

.....

(ii) At a particular instant, in such an experiment, an alpha particle was at a distance of $5.0 \times 10^{-14}\text{m}$ from the gold nucleus.

Calculate the force on the alpha particle at this instant.

(3)

.....

.....

.....

.....

.....

Force =

(Total for Question 16 = 7 marks)



17 A student places two coins, A and B, of the same mass on a flat surface. He pushes coin A towards coin B and observes what happens when they collide. He repeats this several times, recording the collisions on his phone.



*(a) He analyses the recordings and notices that if coin A collides head-on with coin B, then after the collision coin A stops and coin B moves off in the same direction.

Assuming external forces are negligible, discuss whether the collision is elastic.

(3)

.....

.....

.....

.....

.....

.....

.....

.....

DO NOT WRITE IN THIS AREA

DO NOT WRITE IN THIS AREA

DO NOT WRITE IN THIS AREA

DO NOT WRITE IN THIS AREA

DO NOT WRITE IN THIS AREA

DO NOT WRITE IN THIS AREA



(b) If coin A collides with coin B at an angle, both coins move off in different directions after the collision, as shown in the diagram.

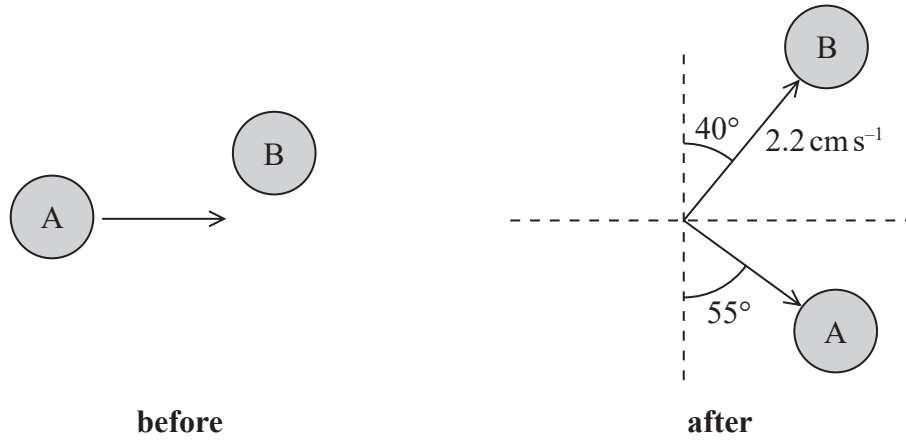

(i) Show that the velocity of coin A immediately after the collision is about 3 cm s^{-1} . (3)

.....

.....

.....

.....

.....

.....

(ii) Determine the initial velocity of coin A just before the collision. (3)

.....

.....

.....

.....

.....

Initial velocity =

(Total for Question 17 = 9 marks)



18 A teacher is demonstrating the properties of an electron beam using an electron deflection tube.

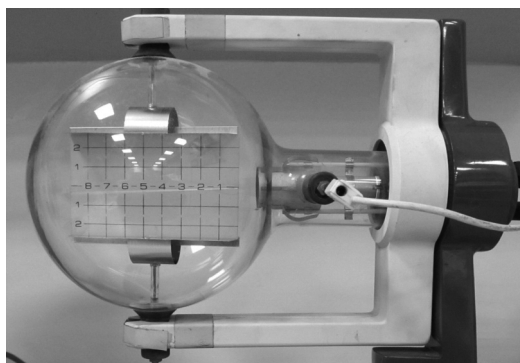

In the tube the path of a beam of electrons can be observed on a grid. The grid is positioned between two metal plates with a potential difference (p.d.) across them.

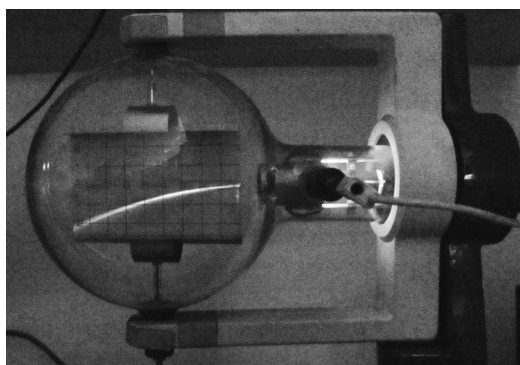

(a) Complete the diagram to show the electric field between the plates.



(3)

DO NOT WRITE IN THIS AREA

DO NOT WRITE IN THIS AREA

DO NOT WRITE IN THIS AREA

DO NOT WRITE IN THIS AREA

DO NOT WRITE IN THIS AREA

DO NOT WRITE IN THIS AREA



- (b) The electron beam undergoes a vertical deflection of 2.0 cm, after travelling a horizontal distance of 8.0 cm.

Calculate the velocity with which the electrons entered the electric field.

(5)

p.d. across plates = 1.50 kV

distance between plates = 5.0 cm

.....

.....

.....

.....

.....

.....

.....

.....

.....

.....

Velocity =

- (c) In another demonstration, a magnetic field of flux density B is applied to the grid. This time the electrons enter the fields with a velocity of $2.4 \times 10^7 \text{ ms}^{-1}$. The p.d. across the plates is changed so that the electric field is in the same direction as before, but so its strength is now $25\,000 \text{ NC}^{-1}$.

B is varied until the electron beam shows no overall deflection.

- (i) Deduce the direction of the magnetic field.

(1)

.....

- (ii) Calculate B when there is no overall deflection of the beam.

(2)

.....

.....

.....

.....

$B = \dots\dots\dots$

(Total for Question 18 = 11 marks)

TOTAL FOR SECTION B = 70 MARKS
TOTAL FOR PAPER = 80 MARKS





DO NOT WRITE IN THIS AREA

DO NOT WRITE IN THIS AREA

DO NOT WRITE IN THIS AREA

DO NOT WRITE IN THIS AREA

DO NOT WRITE IN THIS AREA

DO NOT WRITE IN THIS AREA

BLANK PAGE



DO NOT WRITE IN THIS AREA

DO NOT WRITE IN THIS AREA

DO NOT WRITE IN THIS AREA

DO NOT WRITE IN THIS AREA

DO NOT WRITE IN THIS AREA

DO NOT WRITE IN THIS AREA

BLANK PAGE



List of data, formulae and relationships

Acceleration of free fall	$g = 9.81 \text{ m s}^{-2}$	(close to Earth's surface)
Boltzmann constant	$k = 1.38 \times 10^{-23} \text{ J K}^{-1}$	
Coulomb's law constant	$k = 1/4\pi\epsilon_0$ $= 8.99 \times 10^9 \text{ N m}^2 \text{ C}^{-2}$	
Electron charge	$e = -1.60 \times 10^{-19} \text{ C}$	
Electron mass	$m_e = 9.11 \times 10^{-31} \text{ kg}$	
Electronvolt	$1 \text{ eV} = 1.60 \times 10^{-19} \text{ J}$	
Gravitational constant	$G = 6.67 \times 10^{-11} \text{ N m}^2 \text{ kg}^{-2}$	
Gravitational field strength	$g = 9.81 \text{ N kg}^{-1}$	(close to Earth's surface)
Permittivity of free space	$\epsilon_0 = 8.85 \times 10^{-12} \text{ F m}^{-1}$	
Planck constant	$h = 6.63 \times 10^{-34} \text{ J s}$	
Proton mass	$m_p = 1.67 \times 10^{-27} \text{ kg}$	
Speed of light in a vacuum	$c = 3.00 \times 10^8 \text{ m s}^{-1}$	
Stefan-Boltzmann constant	$\sigma = 5.67 \times 10^{-8} \text{ W m}^{-2} \text{ K}^{-4}$	
Unified atomic mass unit	$u = 1.66 \times 10^{-27} \text{ kg}$	

Unit 1

Mechanics

Kinematic equations of motion	$v = u + at$ $s = ut + \frac{1}{2}at^2$ $v^2 = u^2 + 2as$
Forces	$\Sigma F = ma$ $g = F/m$ $W = mg$
Work and energy	$\Delta W = F\Delta s$ $E_k = \frac{1}{2}mv^2$ $\Delta E_{\text{grav}} = mg\Delta h$

Materials

Stokes' law	$F = 6\pi\eta rv$
Hooke's law	$F = k\Delta x$
Density	$\rho = m/V$
Pressure	$p = F/A$
Young modulus	$E = \sigma/\epsilon$ where Stress $\sigma = F/A$ Strain $\epsilon = \Delta x/x$
Elastic strain energy	$E_{\text{el}} = \frac{1}{2}F\Delta x$

DO NOT WRITE IN THIS AREA

DO NOT WRITE IN THIS AREA

DO NOT WRITE IN THIS AREA

DO NOT WRITE IN THIS AREA

DO NOT WRITE IN THIS AREA

DO NOT WRITE IN THIS AREA



Unit 2

Waves

Wave speed	$v = f\lambda$
Refractive index	${}_1\mu_2 = \sin i / \sin r = v_1 / v_2$

Electricity

Potential difference	$V = W/Q$
----------------------	-----------

Resistance	$R = V/I$
------------	-----------

Electrical power, energy and efficiency	$P = VI$ $P = I^2R$ $P = V^2/R$ $W = VIt$
---	--

$$\% \text{ efficiency} = \frac{\text{useful energy output}}{\text{total energy input}} \times 100$$

$$\% \text{ efficiency} = \frac{\text{useful power output}}{\text{total power input}} \times 100$$

Resistivity	$R = \rho l/A$
-------------	----------------

Current	$I = \Delta Q / \Delta t$ $I = nqvA$
---------	---

Resistors in series	$R = R_1 + R_2 + R_3$
---------------------	-----------------------

Resistors in parallel	$\frac{1}{R} = \frac{1}{R_1} + \frac{1}{R_2} + \frac{1}{R_3}$
-----------------------	---

Quantum physics

Photon model	$E = hf$
--------------	----------

Einstein's photoelectric equation	$hf = \phi + \frac{1}{2}mv_{\max}^2$
-----------------------------------	--------------------------------------



Unit 4

Mechanics

Momentum	$p = mv$
Kinetic energy of a non-relativistic particle	$E_k = p^2/2m$
Motion in a circle	$v = \omega r$ $T = 2\pi/\omega$ $F = ma = mv^2/r$ $a = v^2/r$ $a = r\omega^2$

Fields

Coulomb's law	$F = kQ_1Q_2/r^2$ where $k = 1/4\pi\epsilon_0$
Electric field	$E = F/Q$ $E = kQ/r^2$ $E = V/d$
Capacitance	$C = Q/V$
Energy stored in capacitor	$W = \frac{1}{2}QV$
Capacitor discharge	$Q = Q_0e^{-t/RC}$
In a magnetic field	$F = BIl \sin \theta$ $F = Bqv \sin \theta$ $r = p/BQ$
Faraday's and Lenz's laws	$\epsilon = -d(N\phi)/dt$

Particle physics

Mass-energy	$\Delta E = c^2 \Delta m$
de Broglie wavelength	$\lambda = h/p$

DO NOT WRITE IN THIS AREA

DO NOT WRITE IN THIS AREA

DO NOT WRITE IN THIS AREA

