

Write your name here	
Surname	Other names
Centre Number	Candidate Number
<input type="text"/>	<input type="text"/>
<b>Edexcel GCE</b>	
<b>Physics</b>	
<b>Advanced Subsidiary</b>	
<b>Unit 2: Physics at Work</b>	
Monday 18 January 2010 – Afternoon <b>Time: 1 hour 30 minutes</b>	Paper Reference <b>6PH02/01</b>
<b>You do not need any other materials.</b>	Total Marks
<input type="text"/>	<input type="text"/>

### Instructions

- Use **black** ink or ball-point pen.
- **Fill in the boxes** at the top of this page with your name, centre number and candidate number.
- Answer **all** questions.
- Answer the questions in the spaces provided  
– *there may be more space than you need.*

### Information

- The total mark for this paper is 80.
- The marks for **each** question are shown in brackets  
– *use this as a guide as to how much time to spend on each question.*
- Questions labelled with an **asterisk** (\*) are ones where the quality of your written communication will be assessed  
– *you should take particular care with your spelling, punctuation and grammar, as well as the clarity of expression, on these questions.*
- The list of data, formulae and relationships is printed at the end of this booklet.
- Candidates may use a scientific calculator.

### Advice

- Read each question carefully before you start to answer it.
- Keep an eye on the time.
- Try to answer every question.
- Check your answers if you have time at the end.

Turn over ►

N35081A

©2010 Edexcel Limited.  
1/1/1/1/e2/



edexcel   
advancing learning, changing lives

SECTION A

Answer ALL questions.

For questions 1–10, in Section A, select one answer from A to D and put a cross in the box . If you change your mind, put a line through the box  and then mark your new answer with a cross .

1 Identify which of the following pairs of units are both SI base units.

- A Ampere Hertz
- B Ampere Second
- C Coulomb Hertz
- D Coulomb Second

(Total for Question 1 = 1 mark)

2 The resistance of a length of copper wire is  $6\ \Omega$ . A second piece of copper wire has twice the length and twice the cross-sectional area. The resistance of the second piece of copper wire is

- A  $3\ \Omega$
- B  $6\ \Omega$
- C  $12\ \Omega$
- D  $24\ \Omega$

(Total for Question 2 = 1 mark)

3 Which of the following statements about standing waves is **not** true?

- A particles between adjacent nodes oscillate with varying amplitudes
- B particles between adjacent nodes are moving in phase with each other
- C particles immediately either side of a node are moving in opposite directions
- D particles undergo no disturbance at an antinode

(Total for Question 3 = 1 mark)



- 4 A resistor is connected to a cell. An amount of charge  $Q$  passes through the resistor in a time  $t$ . During this time, the amount of chemical energy converted to electrical energy by the cell is  $E$ .

Select the row of the table which correctly gives the current in the resistor and the e.m.f. of the cell.

		Current	e.m.f.
<input type="checkbox"/>	A	$Q/t$	$EQ$
<input type="checkbox"/>	B	$Qt$	$EQ$
<input type="checkbox"/>	C	$Q/t$	$E/Q$
<input type="checkbox"/>	D	$Qt$	$E/Q$

(Total for Question 4 = 1 mark)



N 3 5 0 8 1 A 0 3 2 4

- 5 A cathode ray oscilloscope can be used to show how the displacement of a wave varies with time. Each square in the horizontal direction represents 5.00 ms.

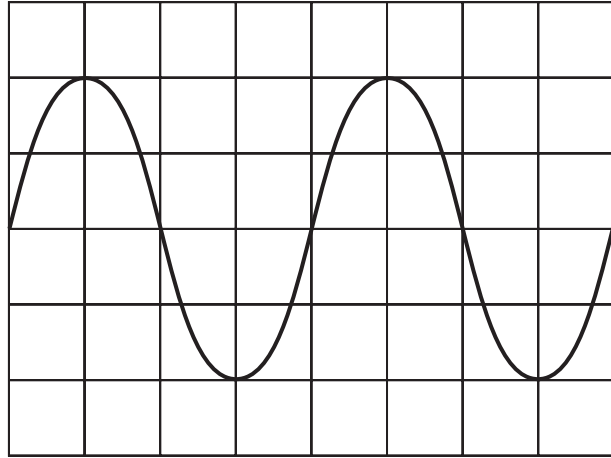

The frequency of the wave is

- A 25 Hz
- B 50 Hz
- C 250 Hz
- D 500 Hz

(Total for Question 5 = 1 mark)



6 The diagram shows the energy transfer for an electric motor.

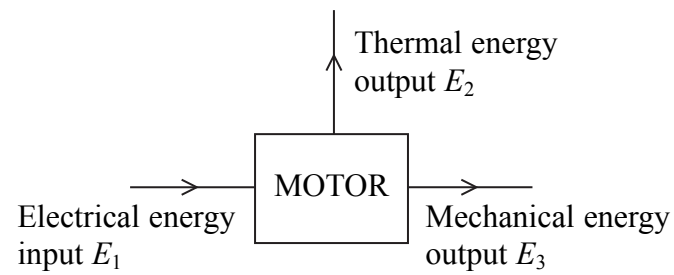

The efficiency of the motor is

- A  $\frac{E_1}{E_2 + E_3}$
- B  $\frac{E_1}{E_2}$
- C  $\frac{E_3}{E_1}$
- D  $\frac{E_2 + E_3}{E_1}$

(Total for Question 6 = 1 mark)

7 An electron is accelerated through a large potential difference and gains a kinetic energy of 47 keV. This energy expressed as joules equals

- A  $7.5 \times 10^{-18}$  J
- B  $7.5 \times 10^{-15}$  J
- C  $2.9 \times 10^{20}$  J
- D  $2.9 \times 10^{23}$  J

(Total for Question 7 = 1 mark)



**8** A source of sound moves away from an observer at a steadily increasing speed. Compared with the original sound, the wavelength reaching the observer will be

- A** greater and decreasing.
- B** greater and increasing.
- C** smaller and decreasing.
- D** smaller and increasing.

(Total for Question 8 = 1 mark)



Use the diagram below for questions 9 and 10.

The diagram shows a ray of light passing through a rectangular glass block.

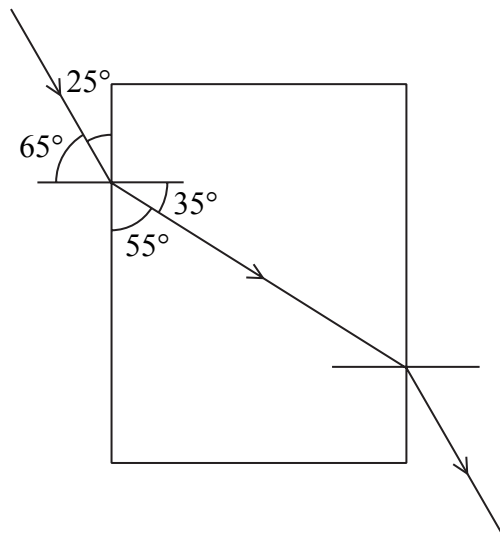

9 Which row in the table below correctly identifies the changes to the properties of the light as it enters the glass block?

		Frequency	Velocity	Wavelength
<input checked="" type="checkbox"/>	A	no change	decreases	decreases
<input checked="" type="checkbox"/>	B	no change	increases	increases
<input checked="" type="checkbox"/>	C	increases	increases	no change
<input checked="" type="checkbox"/>	D	increases	no change	decreases

(Total for Question 9 = 1 mark)

10 The refractive index of the glass is

- A 0.52
- B 0.63
- C 1.6
- D 1.9

(Total for Question 10 = 1 mark)

TOTAL FOR SECTION A = 10 MARKS



**SECTION B**

**Answer ALL questions in the spaces provided.**

**11 (a)** State Ohm's law.

(2)

.....

.....

.....

**(b)** Using the axes below sketch graphs to show how resistance varies with potential difference for a fixed resistor and a 1.5 V filament lamp.

(3)

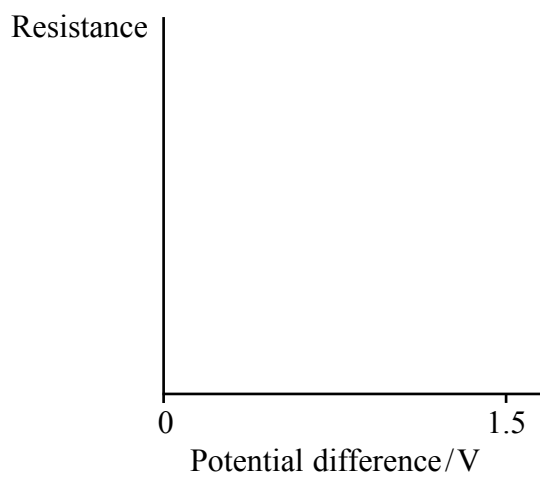

**FIXED RESISTOR**

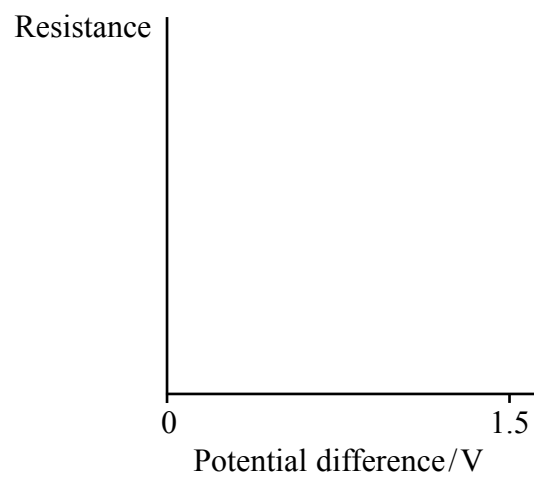

**FILAMENT LAMP**

**(c)** The filament of a lamp is made of metal. Explain why the lamp does not demonstrate Ohm's law.

(2)

.....

.....

.....

.....

**(Total for Question 11 = 7 marks)**





**12** If you look into a fish pond on a bright sunny day, you sometimes cannot see the fish because of the glare of light reflected off the surface. When the sunlight is reflected off the surface of the water it is partially plane-polarised.

(a) State the difference between plane-polarised and unpolarised light.

(1)

.....

.....

.....

(b) Explain how Polaroid sunglasses can enable the fish to be seen.

(3)

.....

.....

.....

.....

.....

.....

.....

(c) State why sound waves cannot be polarised.

(1)

.....

.....

**(Total for Question 12 = 5 marks)**



13 Two resistors are connected in parallel.

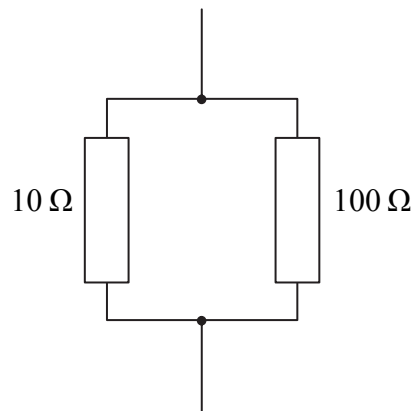

(a) Calculate the resistance of the combination.

(2)

.....

.....

.....

Resistance = .....

(b) This resistance combination is used in an electrical circuit. A student measures the potential difference across the combination with a high resistance voltmeter. Explain why the resistance of the combination is hardly changed by the addition of the voltmeter.

(3)

.....

.....

.....

.....

.....

.....

**(Total for Question 13 = 5 marks)**



**14** Frequencies below the audible range for humans are called infrasound. Infrasound is produced by earthquakes.

(a) Describe how sound waves travel through air.

(3)

.....

.....

.....

.....

(b) State what is meant by frequency.

(1)

.....

.....

(c) An infrasound wave has a wavelength of 1500 m and a frequency of 2.0 Hz.

Calculate the speed of infrasound in the ground.

(2)

.....

.....

Speed = .....

(d) In 2004, a huge earthquake produced a very large tidal wave which swept across the Indian Ocean towards Sri Lanka. Many large animals in Sri Lanka moved away from the coast before the tidal wave hit.

Suggest a reason for the animals behaving in this way.

(2)

.....

.....

.....

.....

**(Total for Question 14 = 8 marks)**



\*15 A circuit is set up as shown in the diagram. The battery has negligible internal resistance.

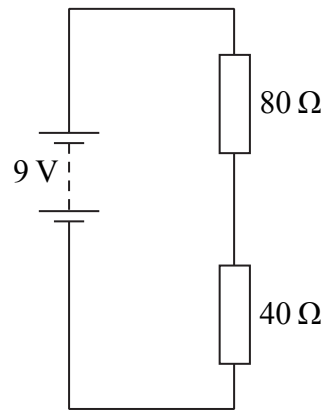

(a) Calculate the potential difference across the 40 Ω resistor.

(2)

.....

.....

.....

.....

Potential difference = .....



(b) A thermistor is connected in parallel with the  $40\ \Omega$  resistor as shown.

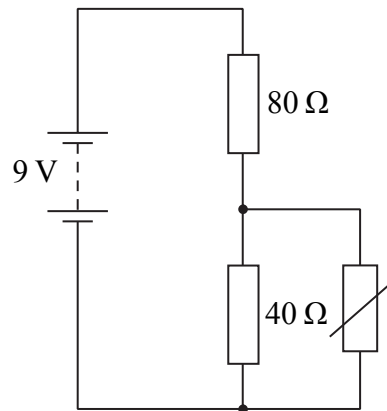

The thermistor is initially at a temperature of  $100\ ^\circ\text{C}$  and its resistance is  $20\ \Omega$ . As the thermistor cools down, its resistance increases.

Explain what happens to the current through the battery as the temperature of the thermistor decreases.

(3)

.....

.....

.....

.....

.....

.....

.....

**(Total for Question 15 = 5 marks)**





17 An integrated circuit uses strips of gold as connectors and strips of silicon as resistors.

A strip of gold of cross-sectional area  $3.0 \times 10^{-6} \text{ m}^2$  carries a current of 8.0 mA. The charge carrier density  $n$  is  $6.0 \times 10^{28} \text{ m}^{-3}$ .

(a) Show that the carrier drift velocity  $v$  for gold is approximately  $3 \times 10^{-7} \text{ m s}^{-1}$ . (2)

.....

.....

.....

(b) An approximate value of  $v$  for a sample of silicon of the same dimensions, carrying the same current, would be  $0.2 \text{ m s}^{-1}$ .

Compare this value with the one for gold and account for the difference in the values. (2)

.....

.....

.....

.....

(c) State and explain what happens to the resistance of a sample of silicon as its temperature increases. (2)

.....

.....

.....

.....

.....

**(Total for Question 17 = 6 marks)**



**\*18** Ready-meals that can be heated in a microwave oven always have the instruction that the food should be stirred properly before eating. This is because ‘hot and cold spots’ within the oven lead to uneven heating of the food.

A microwave source within the oven emits coherent waves in all directions. The waves are reflected off the walls and so the microwaves arrive at one spot by several different routes. The waves interfere with each other and set up standing waves.

(a) Explain what is meant by the following words:

(2)

Coherent .....

Standing wave .....

(b) The diagram shows the path of two microwaves arriving at point S.

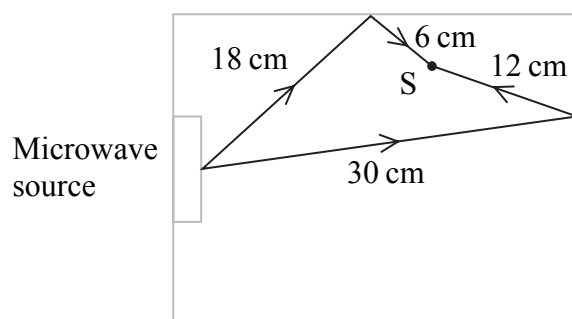

The wavelength of the microwaves is 12 cm.

Explain why S is a ‘cold spot’. Assume that no other microwaves arrive at that point.

(4)

.....  
.....  
.....  
.....  
.....  
.....





(c) Uneven heating can be reduced by placing the food on a rotating turntable. Explain why this will reduce the uneven heating of the food.

(2)

.....

.....

.....

.....

**(Total for Question 18 = 8 marks)**



19 Wavefronts of light change shape when they pass around an edge or through a slit. This means that the light bends and the effect is called diffraction. The longer the wavelength of light, the more the light bends.

(a) The diagram on the left shows red light passing through a slit and undergoing diffraction.

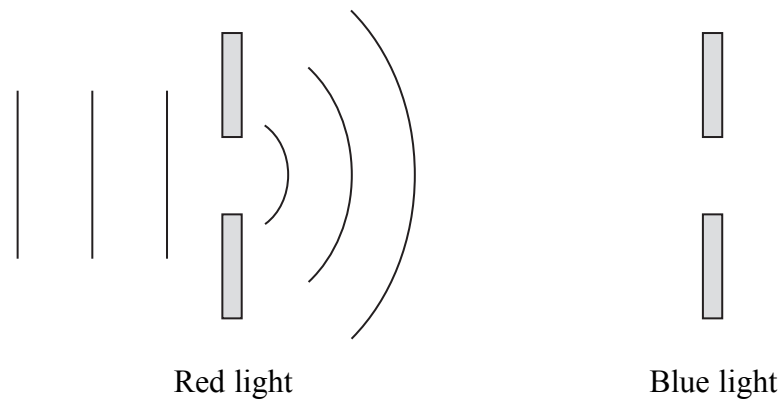

On the diagram on the right, show the same effect for blue light.

(2)

(b) If the red light passes through two slits that are close together, the waves spread out, overlap and add together to produce a pattern of light and dark bands.

Complete the diagram below to show how two overlapping waves produce the pattern of light and dark bands.

(4)

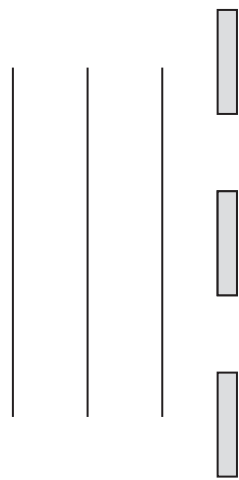

- (c) (i) The spacing between two dark bands in the pattern produced is inversely proportional to the distance between the two slits. Red light is shone through two slits that are separated by 1.2 mm and the dark bands in the pattern are 0.60 mm apart.

Calculate how far apart the dark bands will be if the distance between the two slits is reduced to 0.40 mm.

(2)

.....

.....

.....

Distance between dark bands = .....

- (ii) Describe the effect on the pattern if the distance between the two slits is gradually increased to 1 cm.

(2)

.....

.....

.....

.....

.....

**(Total for Question 19 = 10 marks)**



20 A student uses a battery of e.m.f.  $\mathcal{E}$  and internal resistance  $r$  to investigate how the power delivered to a load  $R$  by a battery, varies with the resistance of the load. The following circuit is used.

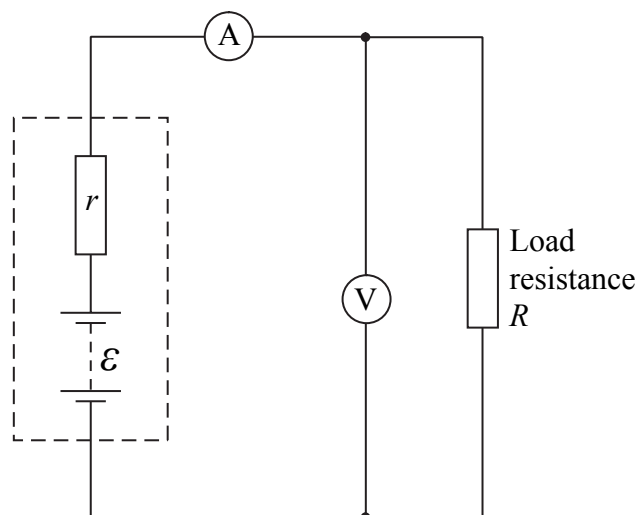

The student uses a spreadsheet to model the behaviour of the circuit.

	A	B	C	D	E	F
1	Load resistance / $\Omega$	E.m.f. / V	Internal resistance / $\Omega$	Current / A	P.d. across load / V	Power in load / W
2	0.00	6.00	0.800	7.50	0.00	0.0
3	0.40	6.00	0.800	5.00	2.00	10.0
4	0.80	6.00	0.800	3.75	3.00	11.3
5	1.20	6.00	0.800	3.00	3.60	10.8
6	1.60	6.00	0.800	2.50	4.00	10.0
7	2.00	6.00	0.800	2.14	4.29	
8	2.40	6.00	0.800	1.88	4.50	8.4



(a) (i) The formula to calculate the value of cell D8 is

$$=B8/(A8+C8)$$

Show why this is the correct formula.

(1)

(ii) Write the formula to calculate the value of cell E4.

(1)

(iii) Calculate the value for cell F7.

(1)

(b) Explain why the p.d. across the load increases as the current decreases.

(3)



(c) (i) Describe how the power delivered to the load varies for load resistances in the range used.

(2)

.....

.....

.....

(ii) A battery of e.m.f. 12 V and internal resistance  $1.6 \Omega$  is now used with the same range of load resistances. Describe how the power delivered to the load resistance will now vary.

(2)

.....

.....

.....

**(Total for Question 20 = 10 marks)**

---

**TOTAL FOR SECTION B = 70 MARKS**

**TOTAL FOR PAPER = 80 MARKS**



**List of data, formulae and relationships**

Acceleration of free fall	$g = 9.81 \text{ m s}^{-2}$	(close to Earth's surface)
Electron charge	$e = -1.60 \times 10^{-19} \text{ C}$	
Electron mass	$m_e = 9.11 \times 10^{-31} \text{ kg}$	
Electronvolt	$1 \text{ eV} = 1.60 \times 10^{-19} \text{ J}$	
Gravitational field strength	$g = 9.81 \text{ N kg}^{-1}$	(close to Earth's surface)
Planck constant	$h = 6.63 \times 10^{-34} \text{ J s}$	
Speed of light in a vacuum	$c = 3.00 \times 10^8 \text{ m s}^{-1}$	

**Unit 1**

*Mechanics*

Kinematic equations of motion	$v = u + at$ $s = ut + \frac{1}{2}at^2$ $v^2 = u^2 + 2as$
Forces	$\Sigma F = ma$ $g = F/m$ $W = mg$
Work and energy	$\Delta W = F\Delta s$ $E_k = \frac{1}{2}mv^2$ $\Delta E_{\text{grav}} = mg\Delta h$

*Materials*

Stokes' law	$F = 6\pi\eta rv$
Hooke's law	$F = k\Delta x$
Density	$\rho = m/V$
Pressure	$p = F/A$
Young's modulus	$E = \sigma/\epsilon$ where Stress $\sigma = F/A$ Strain $\epsilon = \Delta x/x$
Elastic strain energy	$E_{\text{el}} = \frac{1}{2}F\Delta x$



## Unit 2

### Waves

Wave speed  $v = f\lambda$

Refractive index  ${}_1\mu_2 = \sin i / \sin r = v_1/v_2$

### Electricity

Potential difference  $V = W/Q$

Resistance  $R = V/I$

Electrical power, energy and efficiency  
 $P = VI$   
 $P = I^2R$   
 $P = V^2/R$   
 $W = VIt$

$$\% \text{ efficiency} = \frac{\text{useful energy output}}{\text{energy input}} \times 100$$

$$\% \text{ efficiency} = \frac{\text{useful power output}}{\text{power input}} \times 100$$

Resistivity  $R = \rho l/A$

Current  $I = \Delta Q/\Delta t$   
 $I = nqvA$

Resistors in series  $R = R_1 + R_2 + R_3$

Resistors in parallel  $\frac{1}{R} = \frac{1}{R_1} + \frac{1}{R_2} + \frac{1}{R_3}$

### Quantum physics

Photon model  $E = hf$

Einstein's photoelectric equation  $hf = \phi + \frac{1}{2}mv_{\max}^2$

