

Write your name here

Surname

Other names

Centre Number

Candidate Number

**Edexcel GCE**

**Physics**

**Advanced**

**Unit 4: Physics on the Move**

Wednesday 16 January 2013 – Afternoon

**Time: 1 hour 35 minutes**

Paper Reference

**6PH04/01**

**You must have:**

Protractor

Ruler

Total Marks

## Instructions

- Use **black** ink or ball-point pen.
- **Fill in the boxes** at the top of this page with your name, centre number and candidate number.
- Answer **all** questions.
- Answer the questions in the spaces provided  
– *there may be more space than you need.*

## Information

- The total mark for this paper is 80.
- The marks for **each** question are shown in brackets  
– *use this as a guide as to how much time to spend on each question.*
- Questions labelled with an **asterisk** (\*) are ones where the quality of your written communication will be assessed  
– *you should take particular care with your spelling, punctuation and grammar, as well as the clarity of expression, on these questions.*
- The list of data, formulae and relationships is printed at the end of this booklet.
- Candidates may use a scientific calculator.

## Advice

- Read each question carefully before you start to answer it.
- Keep an eye on the time.
- Try to answer every question.
- Check your answers if you have time at the end.

Turn over ►

P41629A

©2013 Pearson Education Ltd.

1/1/1/1/1/1/



**PEARSON**

## SECTION A

Answer ALL questions.

For questions 1–10, in Section A, select one answer from A to D and put a cross in the box . If you change your mind, put a line through the box  and then mark your new answer with a cross .

1 A unit for magnetic flux is the

- A Wb
- B Wb m<sup>2</sup>
- C T
- D T m<sup>-2</sup>

(Total for Question 1 = 1 mark)

2 A body, initially at rest, explodes into two masses  $M_1$  and  $M_2$ . These masses move apart with speeds  $v_1$  and  $v_2$  respectively.

The ratio  $v_1/v_2$  is equal to

- A  $\frac{M_1}{M_2}$
- B  $\frac{M_2}{M_1}$
- C  $\frac{\sqrt{M_1}}{\sqrt{M_2}}$
- D  $\frac{\sqrt{M_2}}{\sqrt{M_1}}$

(Total for Question 2 = 1 mark)

3 Which of the following is a property of a uniform electric field?

- A A field that doesn't change over time.
- B A field that acts equally in all directions.
- C A field that only produces a force on moving charged particles.
- D A field that has the same strength at all points.

(Total for Question 3 = 1 mark)



- 4 A potential difference of 50 V is applied between two identical parallel aluminium plates. The plates are separated by a distance of 10 mm.

Which combination of potential difference and separation would double the electric field strength?

	Separation/mm	Potential difference/ V
<input type="checkbox"/> A	20	100
<input type="checkbox"/> B	20	25
<input type="checkbox"/> C	10	100
<input type="checkbox"/> D	10	25

(Total for Question 4 = 1 mark)

- 5 Which of the following is **not** a vector quantity?

- A electric field strength
- B magnetic flux density
- C momentum
- D potential difference

(Total for Question 5 = 1 mark)



- 6 Two identical spheres of mass  $m$  are both travelling with a speed  $v$  towards each other.

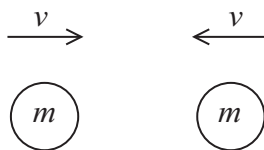

The spheres collide head-on.

Which of the following statements **must** be true after the collision?

- A total momentum =  $2mv$
- B total momentum = 0
- C total kinetic energy =  $mv^2$
- D total kinetic energy = 0

(Total for Question 6 = 1 mark)

- 7 A cyclist travels along a straight horizontal road at a steady speed. A net force of 20 N is then applied for 6 s. The change in momentum of the cyclist is

- A  $3.3 \text{ kg m s}^{-1}$
- B  $26 \text{ kg m s}^{-1}$
- C  $120 \text{ kg m s}^{-1}$
- D  $720 \text{ kg m s}^{-1}$

(Total for Question 7 = 1 mark)

- 8 A conductor of length 50 mm carries a current of 3.0 A at  $30^\circ$  to a magnetic field of magnetic flux density 0.40 T.

The magnitude of the magnetic force acting on the conductor is

- A 0.030 N
- B 0.050 N
- C 30 N
- D 52 N

(Total for Question 8 = 1 mark)



- 9 An alpha particle and a beta particle both move into the same uniform magnetic field which is perpendicular to their direction of motion. The beta particle travels at 15 times the speed of the alpha particle.

The ratio of the force on the beta particle to the force on the alpha particle is

- A 3.7
- B 7.5
- C 30
- D 60

(Total for Question 9 = 1 mark)

---

- 10 The tubes of a linear accelerator (linac) get progressively longer down its length because

- A the accelerating particles become relativistic.
- B the frequency of the applied potential difference changes.
- C the accelerating particles must spend the same time in each tube.
- D the accelerating particles gain mass.

(Total for Question 10 = 1 mark)

---

**TOTAL FOR SECTION A = 10 MARKS**



## SECTION B

Answer ALL questions in the spaces provided.

11 Early in the twentieth century physicists observed the scattering of alpha particles after they had passed through a thin gold foil. This scattering experiment provided evidence for the structure of the atom.

(a) State why it is necessary to remove the air from the apparatus that is used for this experiment. (1)

(b) From the results of such an experiment give **two** conclusions that can be deduced about the nucleus of an atom. (2)

Conclusion 1 .....

Conclusion 2 .....

(c) The diagram shows three  $\alpha$ -particles, all with the same kinetic energy. The path followed by one of the particles is shown. Add to the diagram to show the paths followed by the other two particles. (3)

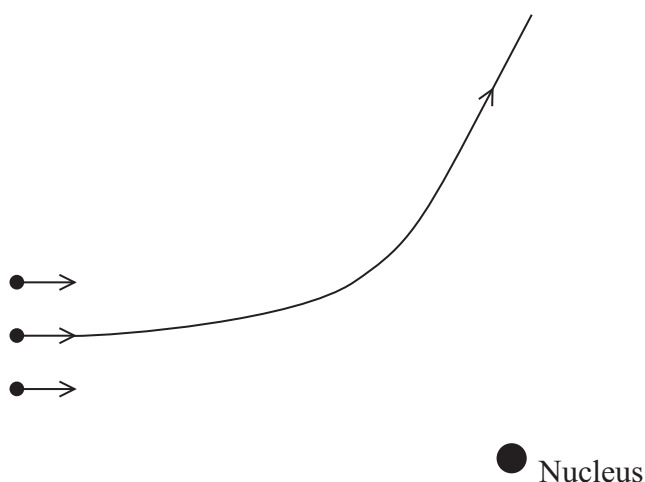

(Total for Question 11 = 6 marks)



12 The electron in a hydrogen atom can be described by a stationary wave which is confined within the atom. This means that the de Broglie wavelength associated with it must be similar to the size of the atom which is of the order of  $10^{-10}$  m.

(a) (i) Calculate the speed of an electron whose de Broglie wavelength is  $1.00 \times 10^{-10}$  m.

(3)

Speed = .....

(ii) Calculate the kinetic energy of this electron in electronvolts.

(3)

Kinetic energy = ..... eV

(b) When  $\beta$  radiation was first discovered, it was suggested that there were electrons in the atomic nucleus, but it was soon realised that this was impossible because the energy of such an electron would be too great.

Suggest why an electron confined within a nucleus would have a much greater energy than the energy calculated in (a)(ii).

(2)

(Total for Question 12 = 8 marks)



- 13 The London Eye consists of a large vertical circle with 32 equally-spaced passenger cabins attached to it. The wheel rotates so that each cabin has a constant speed of  $0.26 \text{ m s}^{-1}$  and moves around a circle of radius 61 m.



- (a) Calculate the time taken for each cabin to make one complete revolution.

(2)

Time = .....

- (b) Calculate the centripetal force acting on each cabin.

mass of cabin =  $9.7 \times 10^3 \text{ kg}$

(2)

Centripetal force = .....





- (c) (i) The diagram shows just the circle and the cabins.  
Draw arrows to show the direction of the centripetal force acting on a person in a cabin when the person is at each of positions **A**, **B** and **C**.

(1)

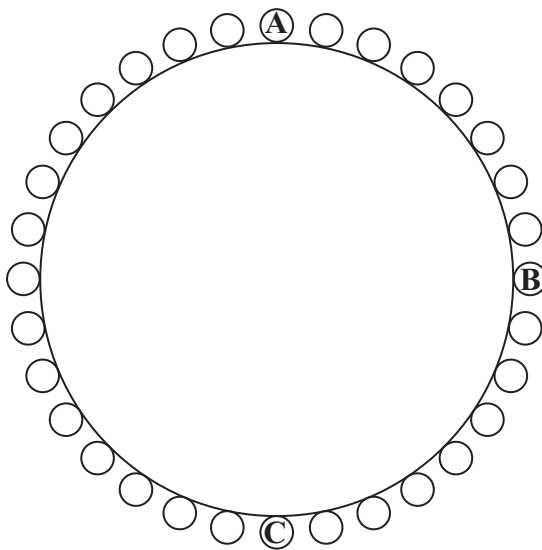

- \*(ii) As the person in a cabin moves around the circle, the normal contact force between the person and the cabin varies.

State the position at which this force will be a maximum and the position at which it will be a minimum. Explain your answers.

(4)

.....

.....

.....

.....

.....

.....

.....

.....

.....

.....

.....

.....

.....

.....

.....

.....

.....

.....

.....

.....

.....

.....

.....

(Total for Question 13 = 9 marks)



- 14 Two identical table tennis balls, M and N, are attached to non-conducting threads and suspended from a point P. The balls are each given the same positive charge and they hang as shown in the diagram. The mass of each ball is 2.7 g.

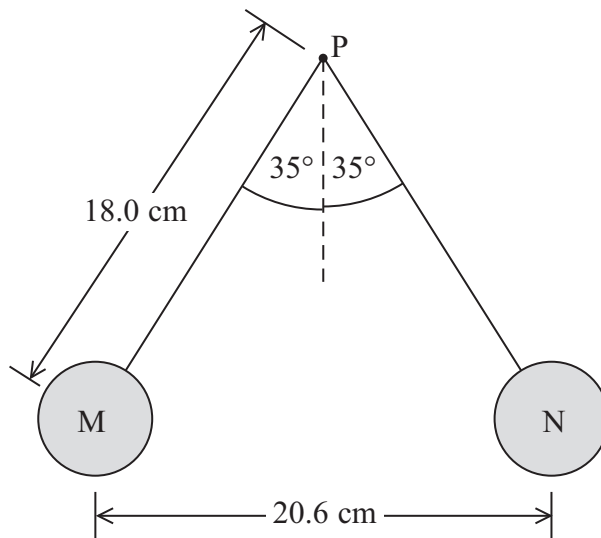

- (a) Draw a free-body force diagram for ball M, label your diagram with the names of the forces.

(2)



(b) (i) Show that the tension in one of the threads is about  $3 \times 10^{-2}$  N. (3)

.....

.....

.....

.....

.....

(ii) Show that the electrostatic force between the balls is about  $2 \times 10^{-2}$  N. (2)

.....

.....

.....

.....

.....

(iii) Calculate the charge on each ball. (3)

.....

.....

.....

.....

.....

Charge = .....

(c) State and explain what would have happened if the charge given to ball M was greater than the charge given to ball N. (2)

.....

.....

.....

.....

.....

(Total for Question 14 = 12 marks)



15 A defibrillator is a machine that is used to correct an irregular heartbeat or to start the heart of someone who is in cardiac arrest.

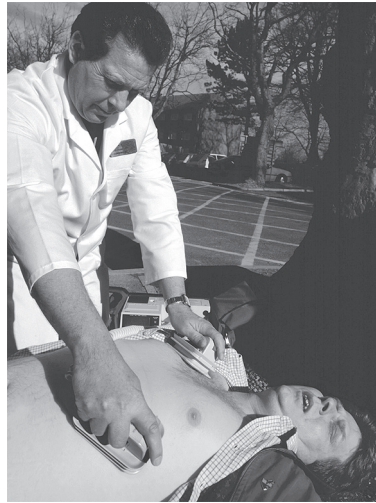

The defibrillator passes a large current through the heart for a short time.

The machine includes a high voltage supply which is used to charge a capacitor. Two defibrillation ‘paddles’ are placed on the chest of the patient and the capacitor is discharged through the patient.

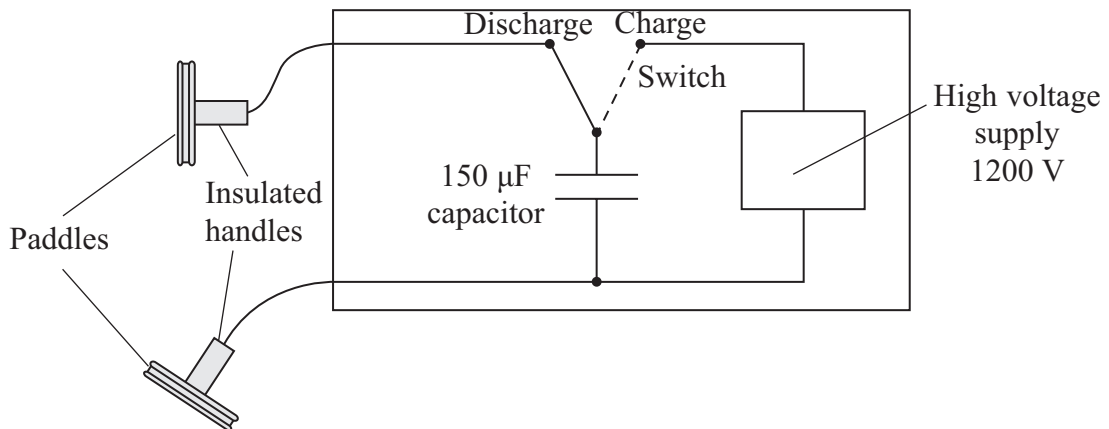

(a) The  $150 \mu\text{F}$  capacitor is first connected across the  $1200 \text{ V}$  supply.

Calculate the charge on the capacitor.

(2)

Charge = .....



(b) Calculate the energy stored in the capacitor.

(2)

.....

.....

.....

Energy stored = .....

(c) When the capacitor discharges there is an initial current of 14 A in the chest of the patient.

(i) Show that the electrical resistance of the body tissue between the paddles is about  $90 \Omega$ .

(1)

.....

.....

(ii) Calculate the time it will take for three quarters of the charge on the capacitor to discharge through the patient.

(3)

.....

.....

.....

.....

.....

Time = .....

(iii) Body resistance varies from person to person. If the body resistance was lower, the initial current would be greater.

State how this lower body resistance affects the charge passed through the body from the defibrillator.

(1)

.....

.....

.....

**(Total for Question 15 = 9 marks)**



16 A teacher demonstrates electromagnetic induction by dropping a bar magnet through a flat coil of wire connected to a data logger.

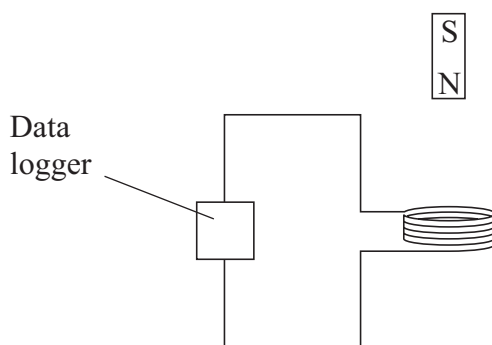

The data from the data logger is used to produce a graph of induced e.m.f. across the coil against time.

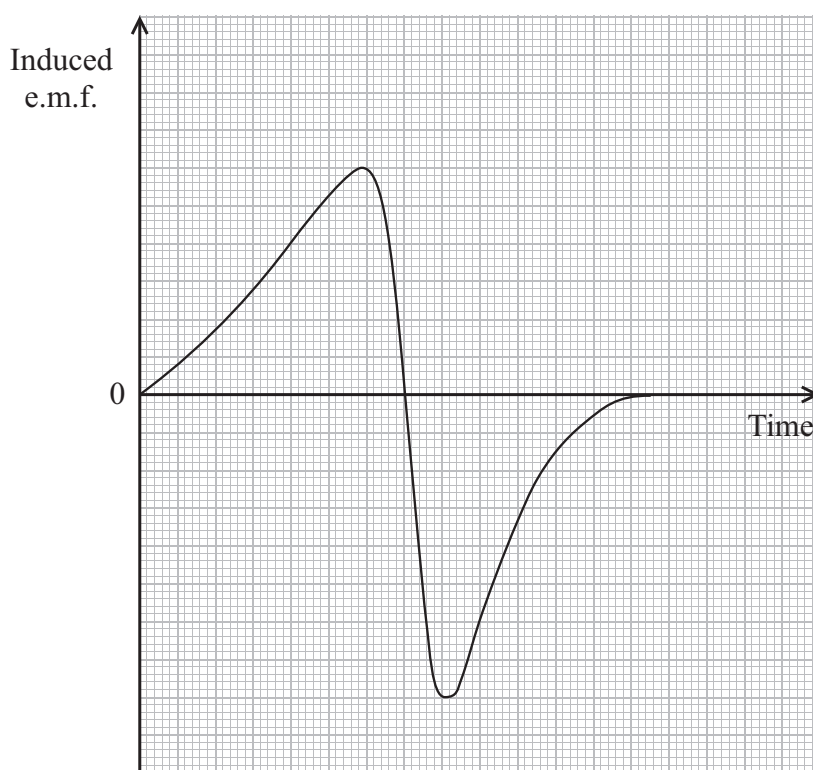

\*(a) Explain the shape of the graph and the relative values on both axes.

(6)

.....

.....

.....

.....

.....

.....

.....

.....



.....

.....

.....

.....

.....

.....

.....

.....

(b) The teacher then sets up another demonstration using a large U-shaped magnet and a very small coil of wire which is again connected to a data logger.

The north pole is vertically above the south pole and the coil is moved along the line AB which is midway between the poles. The magnetic field due to the U-shaped magnet has been drawn. The plane of the coil is horizontal.

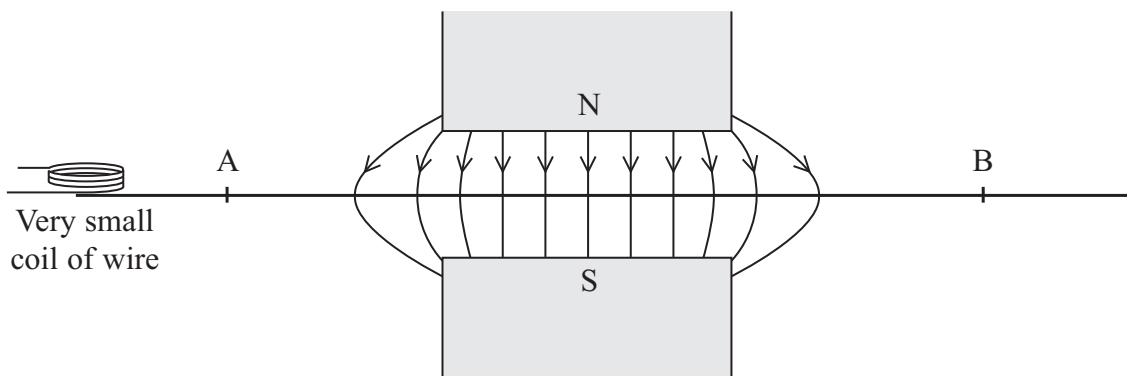

Sketch a graph to show how the e.m.f. induced across the coil varies as the coil moves from A to B at a constant speed.

(4)

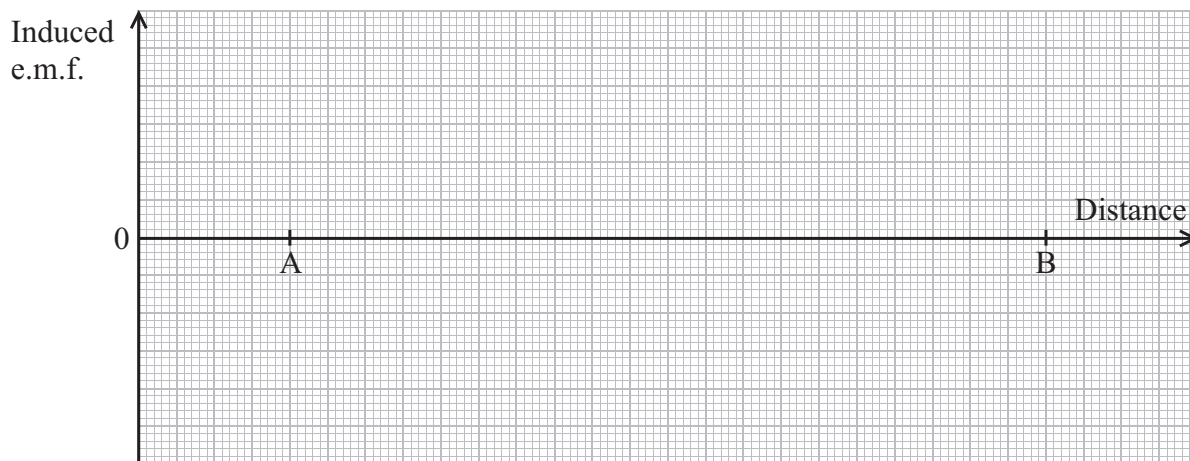

(Total for Question 16 = 10 marks)



17 In 2011 physicists at the Relativistic Heavy Ion Collider (RHIC) announced the creation of nuclei of anti-helium-4 which consists of anti-protons and anti-neutrons instead of protons and neutrons.

(a) ‘Ordinary’ helium-4 is written as  ${}^4_2\text{He}$ .

What do the numbers 4 and 2 represent?

(2)

.....

.....

.....

(b) In the RHIC experiment, nuclei of gold  ${}^{197}_{79}\text{Au}$  travelling at speeds greater than  $2.99 \times 10^8 \text{ m s}^{-1}$ , in opposite directions, collided, releasing energies of up to 200 GeV. After billions of collisions, 18 anti-helium nuclei had been detected.

(i) What is meant by ‘relativistic’ in the collider’s name?

(1)

.....

.....

(ii) State why it is necessary to use very high energies in experiments such as these.

(1)

.....

.....

(iii) Show that the mass of a stationary anti-helium nucleus is about  $4 \text{ GeV}/c^2$ .

(4)

.....

.....

.....

.....

.....

.....

.....

.....

.....

.....

.....





(iv) State why the small number of anti-helium nuclei produced only survive for a fraction of a second.

(1)

.....  
.....

(v) A slow moving anti-helium nucleus meets a slow moving helium nucleus. If they were to combine to produce 2 high energy gamma rays, calculate the frequency of each gamma ray.

(2)

.....  
.....  
.....  
.....

Frequency = .....

(c) There are two families of hadrons, called baryons and mesons. Baryons such as protons are made of three quarks.

(i) Describe the structure of a meson.

(1)

.....  
.....  
.....



(ii) Up quarks have a charge of  $+2/3e$  and down quarks a charge of  $-1/3e$ .  
Describe the quark composition of anti-protons and anti-neutrons and use this to deduce the charge on each of these particles.

(4)

.....

.....

.....

.....

.....

.....

.....

.....

.....

.....

---

**(Total for Question 17 = 16 marks)**

---

**TOTAL FOR SECTION B = 70 MARKS**

**TOTAL FOR PAPER = 80 MARKS**



### List of data, formulae and relationships

Acceleration of free fall	$g = 9.81 \text{ m s}^{-2}$	(close to Earth's surface)
Boltzmann constant	$k = 1.38 \times 10^{-23} \text{ J K}^{-1}$	
Coulomb's law constant	$k = 1/4\pi\epsilon_0$ $= 8.99 \times 10^9 \text{ N m}^2 \text{ C}^{-2}$	
Electron charge	$e = -1.60 \times 10^{-19} \text{ C}$	
Electron mass	$m_e = 9.11 \times 10^{-31} \text{ kg}$	
Electronvolt	$1 \text{ eV} = 1.60 \times 10^{-19} \text{ J}$	
Gravitational constant	$G = 6.67 \times 10^{-11} \text{ N m}^2 \text{ kg}^{-2}$	
Gravitational field strength	$g = 9.81 \text{ N kg}^{-1}$	(close to Earth's surface)
Permittivity of free space	$\epsilon_0 = 8.85 \times 10^{-12} \text{ F m}^{-1}$	
Planck constant	$h = 6.63 \times 10^{-34} \text{ J s}$	
Proton mass	$m_p = 1.67 \times 10^{-27} \text{ kg}$	
Speed of light in a vacuum	$c = 3.00 \times 10^8 \text{ m s}^{-1}$	
Stefan-Boltzmann constant	$\sigma = 5.67 \times 10^{-8} \text{ W m}^{-2} \text{ K}^{-4}$	
Unified atomic mass unit	$u = 1.66 \times 10^{-27} \text{ kg}$	

### Unit 1

#### Mechanics

Kinematic equations of motion	$v = u + at$ $s = ut + \frac{1}{2}at^2$ $v^2 = u^2 + 2as$
Forces	$\Sigma F = ma$ $g = F/m$ $W = mg$
Work and energy	$\Delta W = F\Delta s$ $E_k = \frac{1}{2}mv^2$ $\Delta E_{\text{grav}} = mg\Delta h$

#### Materials

Stokes' law	$F = 6\pi\eta rv$
Hooke's law	$F = k\Delta x$
Density	$\rho = m/V$
Pressure	$p = F/A$
Young modulus	$E = \sigma/\epsilon$ where Stress $\sigma = F/A$ Strain $\epsilon = \Delta x/x$
Elastic strain energy	$E_{\text{el}} = \frac{1}{2}F\Delta x$



## Unit 2

### Waves

Wave speed  $v = f\lambda$

Refractive index  ${}_1\mu_2 = \sin i / \sin r = v_1 / v_2$

### Electricity

Potential difference  $V = W/Q$

Resistance  $R = V/I$

Electrical power, energy and efficiency  
 $P = VI$   
 $P = I^2R$   
 $P = V^2/R$   
 $W = VI t$

$$\% \text{ efficiency} = \frac{\text{useful energy output}}{\text{total energy input}} \times 100$$

$$\% \text{ efficiency} = \frac{\text{useful power output}}{\text{total power input}} \times 100$$

Resistivity  $R = \rho l/A$

Current  
 $I = \Delta Q / \Delta t$   
 $I = nqvA$

Resistors in series  $R = R_1 + R_2 + R_3$

Resistors in parallel  $\frac{1}{R} = \frac{1}{R_1} + \frac{1}{R_2} + \frac{1}{R_3}$

### Quantum physics

Photon model  $E = hf$

Einstein's photoelectric equation  
 $hf = \phi + \frac{1}{2}mv_{\max}^2$



## Unit 4

### Mechanics

Momentum	$p = mv$
Kinetic energy of a non-relativistic particle	$E_k = p^2/2m$
Motion in a circle	$v = \omega r$ $T = 2\pi/\omega$ $F = ma = mv^2/r$ $a = v^2/r$ $a = r\omega^2$

### Fields

Coulomb's law	$F = kQ_1Q_2/r^2$ where $k = 1/4\pi\epsilon_0$
Electric field	$E = F/Q$ $E = kQ/r^2$ $E = V/d$
Capacitance	$C = Q/V$
Energy stored in capacitor	$W = \frac{1}{2}QV$
Capacitor discharge	$Q = Q_0 e^{-t/RC}$
In a magnetic field	$F = BIl \sin \theta$ $F = Bqv \sin \theta$ $r = p/BQ$
Faraday's and Lenz's Laws	$\epsilon = -d(N\phi)/dt$

### Particle physics

Mass-energy	$\Delta E = c^2 \Delta m$
de Broglie wavelength	$\lambda = h/p$



**BLANK PAGE**



**BLANK PAGE**



**BLANK PAGE**

